

Model 976

7.1 Channel/4K HDR

Preamp Processor

Owner's Manual

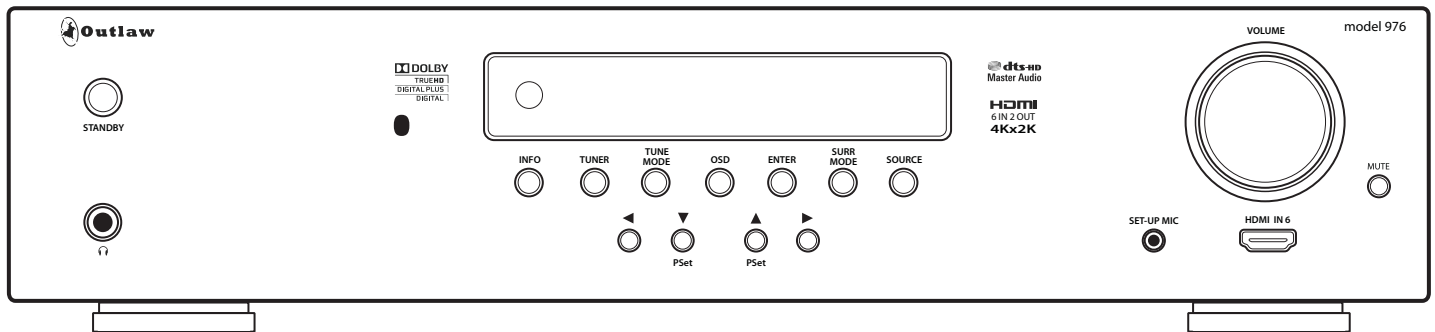

Please Read First



CAUTION: To reduce the risk of electric shock, do not remove the cover. No user serviceable parts inside. Refer to qualified personnel

WARNING: To reduce the risk of fire or electric shock, do not expose this appliance to rain or moisture.



The lightning flash with arrowhead, within an equilateral triangle, is intended to alert the user to the presence of un-insulated "dangerous voltage" within the product's enclosure that may be of sufficient magnitude to constitute a risk of electrical shock to persons.



The exclamation point within an equilateral triangle is intended to alert the user to the presence of important operating maintenance (servicing) instructions in the literature accompanying the appliance.

WARNING: Important Safeguards

Read Instructions All the safety and operating instructions should be read before the unit is operated.

Retain Instructions The safety and operating instructions should be retained for future reference.

Heed Warnings All warnings on the unit and in the operating instructions should be adhered to.

Follow Instructions All operating and use instructions should be followed.

Cleaning Unplug the unit from the wall outlet before cleaning. The unit should be cleaned only as recommended by the manufacturer.

Attachments Do not use attachments not recommended by the unit manufacturer as they may cause hazards.

Water and Moisture Do not use the unit near water—for example, near a bath tub, wash bowl, kitchen sink, or laundry tub; in a wet basement; or near a swimming pool.

Accessories Do not place the unit on an unstable cart, stand, tripod, bracket, or table. The unit may fall, causing serious injury to a child or adult, and serious damage to the unit. Any mounting of the unit should follow the manufacturer's instructions, and should use a mounting accessory recommended by the manufacturer.

Ventilation Slots and openings in the cabinet are provided for ventilation and to ensure reliable operation of the unit and to protect it from over-heating, and these openings must not be blocked or covered. The openings should never be blocked by placing the unit on a bed, sofa, rug, or other similar surface. The unit should not be placed in a built-in installation such as a bookcase or rack unless proper ventilation is provided. There should be free space of at least 16 cm (6 in.) and an opening behind the unit.

Power Sources The unit should be operated only from the type of power source indicated on the marking label. If you are not sure of the type of power supplied to your home, consult your unit dealer or local power company.

Grounding or Polarization The unit may be equipped with a polarized alternating current line plug (a plug having one blade wider than the other). This plug will fit into a power outlet only one way. This is a safety feature. If you are unable to insert the plug fully into the outlet, try reversing the plug. If the plug should still fail to fit, contact a licensed electrician to replace your obsolete outlet. Do not defeat the safety purpose of the polarized plug.

Power-Cord Protection Power-supply cords should be routed so that they are not likely to be walked on or pinched by items placed upon or against them, paying particular attention to cords where they enter a plug, or a convenience receptacle, and the point where they exit from the unit.

Outdoor Antenna Grounding If an outside antenna or cable system is connected to the unit, be sure the antenna or cable system is grounded so as to provide some protection against voltage surges and built-up static charges. Article 810 of the National Electrical Code, ANSI/NFPA 70, provides information with regard to proper grounding of the mast and supporting structure, grounding of the lead-in wire to an antenna-discharge unit, size of grounding conductors, location of antenna-discharge unit, connection to grounding electrodes, and requirements for the grounding electrode.

Lightning For added protection for the unit during a lightning storm, or when it is left unattended and unused for long periods of time, unplug it from the wall outlet and disconnect the antenna or cable system. This will prevent damage to the unit due to lightning and power-line surges.

Power Lines An outside antenna system should not be located in the vicinity of overhead power lines or other electric light or power circuits, or where it can fall into such power lines or circuits. When installing an outside antenna system, extreme care should be taken to keep from touching such power lines or circuits as contact with them might be fatal.

Overloading Do not overload wall outlets, extension cords, or integral convenience receptacles as this can result in a risk of fire or electric shock.

Object and Liquid Entry Never push objects of any kind into the unit through openings as they may touch dangerous voltage points or short-out parts that could result in a fire or electric shock. Never spill liquid of any kind on the unit.

Servicing Do not attempt to service the unit yourself as opening or removing covers may expose you to dangerous voltage or other hazards. Refer all servicing to Outlaw Audio.

Damage Requiring Service Unplug the unit from the wall outlet and refer servicing to qualified service personnel under the following conditions:

- When the power-supply cord or plug is damaged,
- If liquid has been spilled, or objects have fallen into the unit,
- If the unit has been exposed to rain or water,
- If the unit does not operate normally by following the operating instructions. Adjust only those controls that are covered by the operating instructions as an improper adjustment of other controls may result in damage and will often require extensive work by a qualified technician to restore the unit to its normal operation,
- If the Model 976 has been dropped or damaged in any way, the unit should be examined by qualified service personnel.
- When the unit exhibits a distinct change in performance—this indicates a need for service.

Wall or Ceiling Mounting The unit should be mounted to a wall or ceiling only as recommended by the manufacturer.

Heat The unit should be situated away from heat sources such as produce heat.

IMPORTANT SAFETY NOTE Before connecting a new component such as the Model 976 to your audio or home theater system it is always good practice to make certain that all components are turned off, and preferably unplugged from their AC power source. Many modern electronics products feature automatic turn-on circuits that may be activated during an installation, causing the potential for damage to electronic components and/or speakers. Such damage is not covered by product warranties and Outlaw Audio specifically disclaims responsibility for any such damage.

Precautions

Verify The Line Voltage

Your new Model 976 has been factory configured for 120 (+/-3%) volt AC lines. Connecting the unit to a line voltage other than that for which it is intended can create a safety and fire hazard, and may damage the Model 976. If you have any questions about the voltage requirements for your specific model, or about the line voltage in your area, contact Outlaw Audio before plugging the unit into a wall outlet.

It is always a good idea to avoid using any audio or video equipment on the same AC circuit as equipment with motors, such as air conditioners or refrigerators. This will lessen the possibility of power variation and electrical start-up noise affecting your sound system.

Power Cord

The removable power cord that is shipped with the Model 976 is specifically designed to be used with this product. DO NOT use any other power cord, as that may reduce the unit's performance and possibly create a safety hazard. In particular, DO NOT use standard IEC type power cords designed for computers and other business equipment products, as they have a three prong plug that is not meant for use with the 976. Should the power cord require replacement, use an identical type, or contact Outlaw Audio for service.

Handle the AC Power Cord Gently

When disconnecting the power cord from an AC outlet, always pull the plug, never pull the cord. If you do not intend to use the Model 976 for any considerable length of time, disconnect the plug from the AC outlet. If the power cord is replaced, make certain that it is of similar gauge. As with all electrical devices, do not run power cords under rugs or carpets or place heavy objects on them. Damaged power cords should be replaced immediately with cords meeting factory specifications.

Wiring

Cables that are run inside of walls should have the appropriate markings to indicate compliance with, and listing by the UL, CSA or other standards required by the UL, CSA, NEC or your local building code. Questions about cables inside of walls should be referred to a qualified custom installer, or a licensed electrician or low-voltage contractor.

Installation Location

To assure proper operation and to avoid the potential for safety hazards, place the unit on a firm and level surface capable of supporting its weight. When placing the unit on a shelf, be certain that the shelf and any mounting hardware can support the weight of the unit and any additional items in the equipment rack, or on the shelf.

When positioning the Model 976 in its final location, make certain that it has adequate ventilation on all sides, as well as on the top and bottom. In particular, it is a good idea to provide at least two or three inches of room above the unit for air circulation. DO NOT place CDs, DVDs, videotapes, owner's manuals, or other paper on top of, or beneath, the unit, or in-between multiple amplifiers in a stack. This will block airflow, causing heat build-up, degraded performance, and may create a possible fire hazard.

If the unit is to be enclosed in a cabinet or rack, make certain there is adequate air circulation. Sufficient ventilation should be provided so that hot air may exit, and cool air may enter the cabinet. In some instances, a small cooling fan may be required to insure adequate airflow through the cabinet. If you are in doubt as to the ventilation requirements for your specific installation, please contact us. Also, do not place the Model 976 directly on a carpeted surface, as this will inhibit airflow underneath as well as create a potential fire hazard.

Avoid installation in humid locations, in extremely hot or cold locations, or in areas that are exposed to direct sunlight or space heating equipment.

Do Not Open The Cabinet

There are no user serviceable components inside this product. Opening the cabinet may present a shock hazard, and any modification to the product will void your guarantee. If water or any metal object, such as a paper clip, coin or a staple, accidentally falls inside the unit, disconnect it from the AC power source immediately, and contact Outlaw Audio for further instructions.

Recording Copyright

Recording of copyrighted material for other than personal use is illegal without permission of the copyright holder.

Note to CATV system installer

This reminder is provided to call the CATV system installer's attention to Article 820-40 of the NEC, ANSI/NFPA 70, which provides guidelines for proper to the grounding system of the building, as close to the point of cable entry as practical.

FCC Information for User

CAUTION: ANY changes or modifications not expressly approved by the party responsible for compliance could void the user's authority to operate the equipment.

This equipment has been tested and found to comply with the limits for a Class B digital device, pursuant to Part 15 of the FCC Rules. These limits are designed to provide reasonable protection against harmful interference in a residential installation.

This equipment generates, uses and can radiate radio frequency energy and, if not installed and used in accordance with the instructions, may cause harmful interference to radio communications. However, there is no guarantee that interference will not occur in a particular installation.

If this equipment does cause harmful interference to radio or television reception, which can be determined by turning the equipment off and on, the user is encouraged to try to correct the interference by one or more of the following measures:

- Reorient or relocate the receiving antenna.
- Increase the separation between the equipment and receiver.
- Connect the equipment into an outlet on a circuit different from that to which the receiver is connected.

Outdoor Antenna Installation

Safe Antenna and Cable Connection

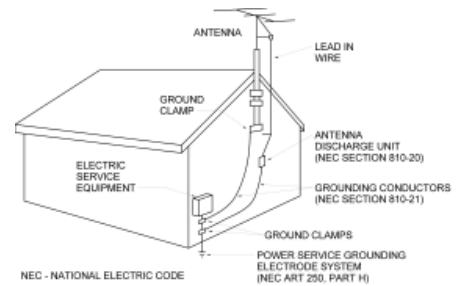

If an outside antenna or cable system is connected to the equipment, be sure the antenna or cable system is grounded so as to provide some protection against built up static charges and voltage surges. Section 810 of the national Electrical Code, ANSI/NFPA 70 (in Canada, part 1 of the Canadian Electrical Code) provides information with respect to proper grounding of the mast and supporting structure, grounding of the lead-in wire to an antenna discharge unit, size of grounding conductors, location of antenna discharge unit, connection to grounding electrodes and requirements for the grounding electrode.

Keep Antenna Clear of High Voltage Power Lines or Circuits

An outside antenna system should be located well away from power lines, electric light or power circuits and where it will never come into contact with these power sources if it should happen to fall. When installing an outside antenna, extreme care should be taken to avoid touching power lines, circuits or other power sources as this could be fatal. Because of the hazards involved, antenna installation should be left to a professional.

Unpacking

Save all packing materials

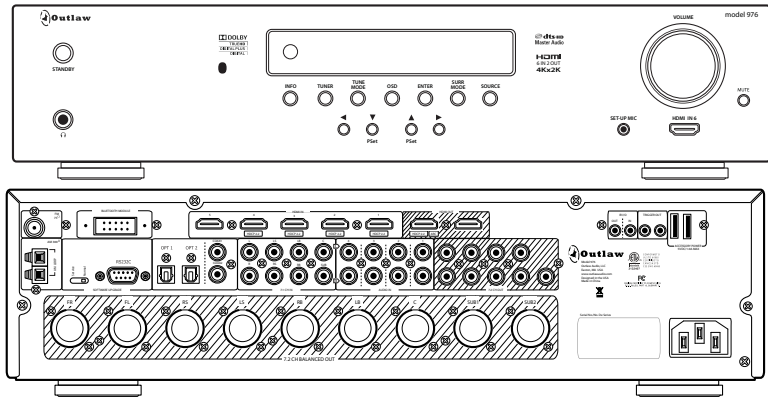
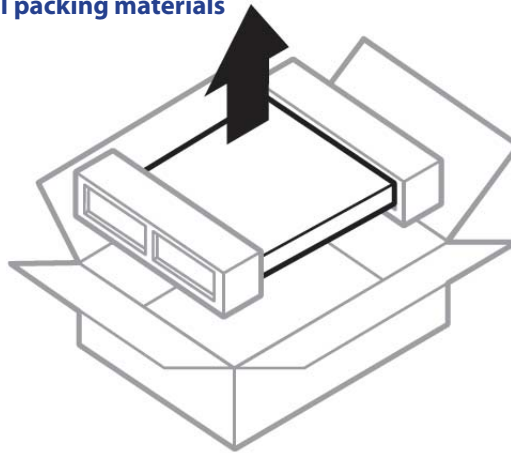

Your Model 976 comes in a carton and packing materials designed specifically to cushion it from shocks and vibration commonly encountered in shipping. We strongly suggest that you save the carton and packing materials, and use them again if you move or if the unit ever needs to be shipped back to us for any reason.

To minimize the size of the carton in storage, you may wish to flatten it by carefully opening the top and bottom flaps and folding the carton flat. Other cardboard inserts may be stored in the same manner. Packing materials that cannot be collapsed should be saved along with the carton in a plastic bag.

Be careful when lifting and handling the Model 976. The unit itself is not heavy, but the connectors on the rear panel and the controls on the front panel can be damaged by minor impacts.

Record your Model 976's serial number and date of purchase here. The serial number is found on the back panel.

Serial Number

Date of Purchase

The contents of this manual are Copyright © 2017 by Outlaw Audio, LLC., and may not be duplicated or reproduced by any means, whether physical, electronic or otherwise without prior written consent from Outlaw Audio, LLC.

Outlaw Audio and the Outlaw Audio logo are registered trademarks of Outlaw Audio, Inc. "Dolby," "Pro Logic," "TrueHD" and the double-D symbol are trademarks of Dolby Laboratories.

© Dolby Laboratories, Inc. All rights reserved.

"DTS" and "DTS Digital Surround" are trademarks of Digital Theater Systems, Inc.

© Digital Theater Systems, Inc. All rights reserved.

Specifications are those in effect at the time of printing. Outlaw Audio, LLC reserves the right to change specifications or designs at any time without notice, and without obligation to modify existing units.

Table of Contents

Please Read First

- 2 WARNING: Important Safeguards
- 3 Precautions
- 3 Outdoor Antenna Installation
- 4 Unpacking

Chapter 1

Model 976 7.1 Channel Preamp/Processor

- 6 Model 976 Features
- 7 Accessories
- 8 Model 976 Front Panel
- 9 Model 976 Rear Panel
- 10 Remote Control
- 12 Front Panel Display
- 13 Audio Formats and Listening Modes
- 15 Speaker Setup Tips

Chapter 2

Connecting Your Model 976

- 17 Connecting Audio
- 19 Connecting Video
- 20 Accessory and Antenna Connections
- 21 External Amplifier Connections
- 21 Power & IR Control Connections
- 22 Power Connection

Chapter 3

System Setup

- 23 Menu Navigation
- 24 Main Menu
- 25 System Setup
- 26 Input Setup
- 27 Speaker Setup
- 31 EQ Adjust
- 32 Audio Setup

Chapter 4

Operation

- 33 Power
- 33 Selecting a Source
- 34 Volume Control
- 34 Muting
- 34 Changing the Surround Mode
- 35 Switching to Stereo
- 36 Adjusting Tone Controls
- 36 Adjusting Lip Sync Delay
- 36 Activating Night Mode (DRC)
- 37 Adjusting Channel Levels
- 38 Engaging EQ
- 38 Listening With Headphones
- 38 Setting Sleep Timer

Chapter 5

Tuner Operation

- 39 Select Tuner and Band
- 39 Tune a Station Manually
- 40 Create Memory Presets
- 40 Select a Preset Station
- 40 Tune Stations Directly
- 41 Select FM Mono

Chapter 6

Care and Maintenance

- 42 Cleaning
- 42 When You Are Away
- 43 System Reset
- 44 Troubleshooting
- 45 Specifications
- 46 Model 976 Connection Record Chart
- 47 Outlaw Audio Limited Warranty

Model 976

7.1 Channel Preamp/Processor

Thank you for purchasing the Outlaw Audio Model 976. This 7.1 channel pre-amp/processor is our response to enthusiasts who requested a simpler pre/pro, one with only the functions they really need, such as industry-standard DTS and Dolby surround technologies, HDMI switching, high-quality digital-to-analog conversion, 4K and HDR capabilities, as well as multiple crossover point settings. This simplicity not only makes the Model 976 compact and affordable, it also makes it easier to use.

Model 976 Front Panel

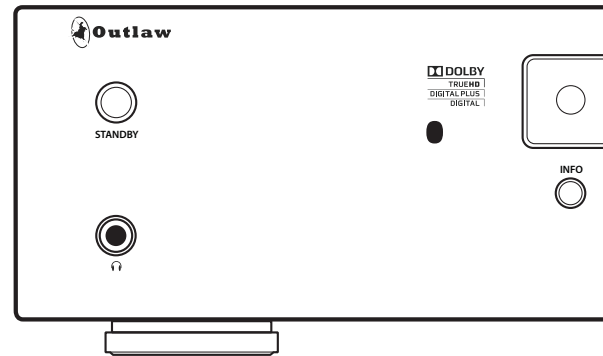

Chapter 1 Contents

- 6 Model 976 Features
- 7 Accessories
- 8 Model 976 Front Panel
- 9 Model 976 Rear Panel
- 10 Remote Control
- 12 Front Panel Display
- 13 Audio Formats and Listening Modes
- 15 Speaker Setup Tips

In order to get maximum performance from your Model 976, please take a few minutes to read this manual. It tells you everything you need to know to connect this product. By following the steps we list and explain here, you will get the best possible performance from your speakers, amplifier(s), and subwoofer, as well as the best possible picture and sound from your source components.

If you have any questions about this product, its installation or operation, please contact us via e-mail at customerservice@outlawaudio.com or via telephone at **866-OUTLAWS** (688-5297).

IMPORTANT: The Model 976 is shipped from the factory with the following default settings.

Output Configuration	7.1
Loudspeaker Size	Small
All Crossovers	80 Hz
Volume	-40dB

After reading the rest of this manual, please refer to pages 23-32 to adjust these settings.

Your new Outlaw Audio preamp/processor is a high-performance audio device, designed to work with practically any of the wide variety of amplifiers and source devices on the market today. Whether your source is a Blu-ray Disc with a 7.1-channel DTS-HD Master Audio lossless soundtrack or even an audiophile CD player, the Model 976's audio processing technology can handle it correctly.

The Model 976 features:

- **6 HDMI Inputs (4 HDMI 2.0b, 2 HDMI 1.4b)**
Each input is assignable, providing comprehensive system connectivity.
- **2 HDMI Outputs (1 HDMI 2.0b with ARC)**
Audio Return Channel receives audio signals from a connected TV.
- **4 Digital Inputs (2 coaxial, 2 optical)**
Each input is assignable, providing comprehensive system connectivity.
- **7.1 Analog Audio Input**
Pure pass-thru analog circuitry for maintaining signal purity.

Accessories

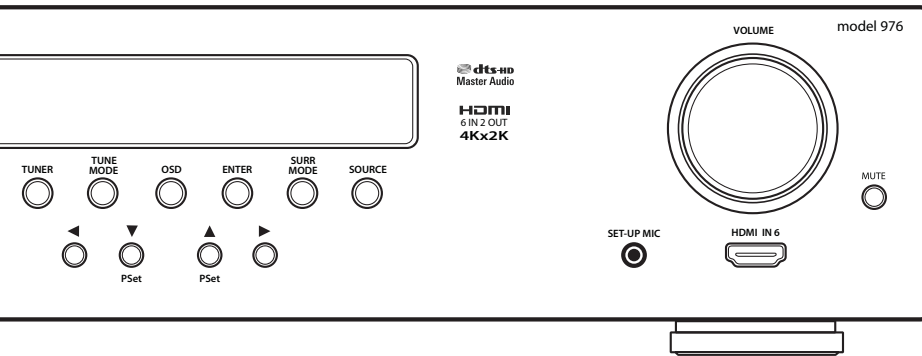

HDMI connectivity



2-channel to 5.1 / 2.0 or 5.1 to 7.1 surround sound



5.1 and 7.1 digital surround formats

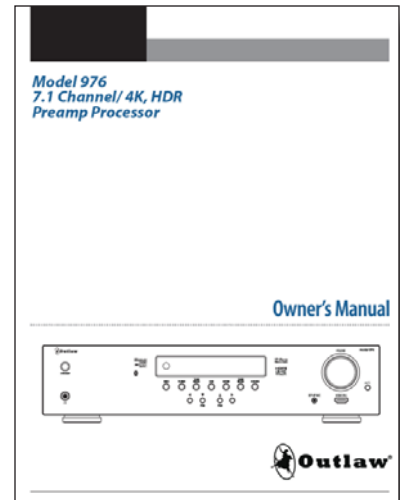

- **Balanced XLR Output(s)**
For those who are doing long runs of interconnect cables, or experience noise due to interference.
- **4 Stereo Analog Audio Inputs**
For easy connection to audio devices that do not offer digital output, such as iPod docks and phono preamps.
- **High Definition Video**
Capable of reproducing standard and hi-res video as well as 4K, HDR-10, and Dolby Vision content.
- **High-performance AM/FM Stereo tuner**
Includes memories for 20 FM and AM presets.
- **Dolby TrueHD, Dolby Digital Plus, and Dolby Digital decoding***; **DTS-HD Master Audio, DTS-HD High-Resolution Audio and DTS decoding****
Decodes all current 5.1 and 7.1 surround-sound formats.
- **Dolby and DTS post processing**
Converts two-channel audio from music and movies into realistic 5.1 or 7.1 surround sound
- **192 kHz 24-bit DAC's for all channels**
For high performance audio quality.
- **On Screen Display (via HDMI only)**
Provides access to all setup and adjustment menus.
- **Built in 10 Band EQ**
For correcting any faults in your listening environment with separate controls for each channel.
- **Separately adjustable crossover points**
For the best possible bass reproduction, different crossover points can be set for front left/right, center, surround, and surround back channels.
- **Brushed aluminum remote control**
Controls the Model 976.
- **Low-voltage trigger output**
Provides automatic turn on/off of compatible power amplifiers or relay-controlled products such as projection screens, blinds and lighting systems.

* Manufactured under license from Dolby Laboratories.

** Manufactured under license from Digital Theater Systems, Inc. US Pat. No. 5,451,942 and other worldwide patents issues and pending.

"Dolby," "Pro Logic," "TrueHD" and the double-D symbol are trademarks of Dolby Laboratories. © Dolby Laboratories, Inc. All rights reserved.

"DTS" and "DTS Digital Surround" are trademarks of Digital Theater Systems, Inc. © Digital Theater Systems, Inc. All rights reserved.

After you unpack the Model 976, please check to make sure the following accessories are in the box:

- Owner's Manual
- Remote Control with Batteries
- Setup Microphone
- AC Power Cord
- FM Antenna
- AM Loop Antenna

If any of the above is missing from your shipment, please contact Outlaw Audio immediately.

Model 976 Front Panel

Model 976 Front Panel controls

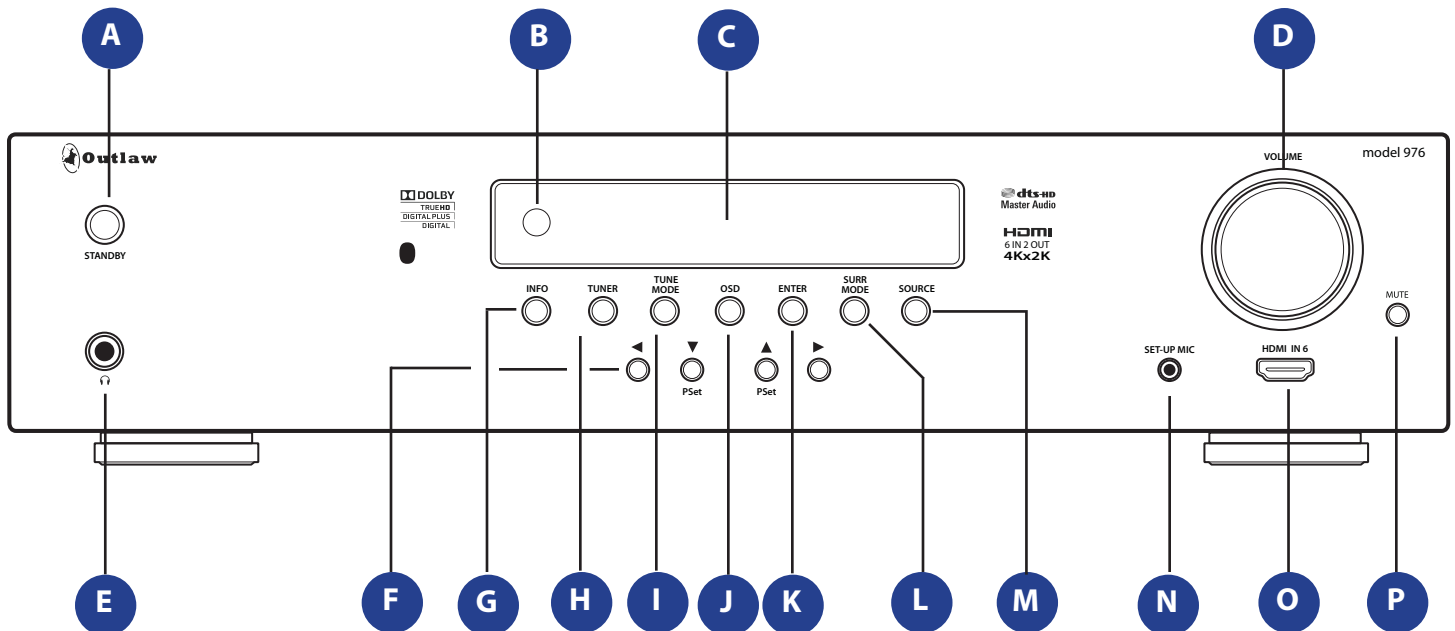

Before you connect any audio or video components to the Model 976, it's important to understand how the different buttons, switches, and connections work. The following two sections offer a brief explanation of the front and rear panel components of the Model 976.

- A. STANDBY power button** (see page 33)
Pressing this button brings the unit in and out of standby. When the unit is on, the blue ring around the button glows brightly and the front panel display illuminates. When the unit is in standby, the blue ring glows dimly, and everything turns off except for the IR sensor and circuitry.
- B. IR Sensor** (see page 21)
The IR sensor receives commands from the remote control. Do not block or cover it. If the unit is inside a cabinet or behind tinted glass doors, you may need to use an optional external IR sensor.
- C. Front panel display** (see page 12)
Indicates program source, DSP mode, tuner preset and/or frequency, digital input, volume level, and other preamp/processor/tuner operating information. The display is dimmable.
- D. Volume control** (see page 34)
Adjusts the volume level for the pre-outputs and the headphone jack.
- E. Headphone jack** (see page 38)
Connect a 1/4 inch phone plug (or an adaptor) here for headphone listening.
- F. Cursor Arrows** (see pages 23, 26, 37, 39, and 40)
These buttons provide navigation control. The Up and Down buttons also provide Tuner Preset Up and Preset Down controls.
- G. INFO button**
Pushing this button causes the front panel display to show the input being monitored as well as the incoming audio format.
- H. TUNER button** (see pages 33 and 39)
This button selects the radio tuner. The front panel display will show which band (AM or FM) is active, and the frequency of the station currently tuned. Pushing the button again will toggle between AM and FM.
- I. TUNE MODE button** (see page 41)
Toggles between stereo and mono FM tuning modes when the tuner is selected source and the FM band is selected.
- J. OSD button** (see page 23)
This button provides access to the on-screen setup menu.
- K. Enter button** (see page 23)
When navigating the setup menu, pressing this button will access sub-menus or select highlighted options.
- L. SURR MODE button** (see pages 34-35)
Press this button repeatedly to activate matrix surround sound modes and choose among the various surround modes provided by the Model 976. The modes that are available will depend on whether you are listening to a 2-channel signal or a 5.1 or 7.1 signal, and also on the loudspeaker configuration you are using.
- M. Source button** (see page 33)
This button cycles through the input sources.
- N. Setup Mic jack** (see page 30)
Connect the setup microphone to this input jack to use the automatic setup tool.
- O. HDMI IN 6** (see page 19)
Front HDMI input, HD compatible. Connect the HDMI output of HD sources.
- P. MUTE button** (see page 34)
This button mutes the pre- outputs and the headphone output.

Model 976 Rear Panel

Model 976 Rear Panel connections and switches

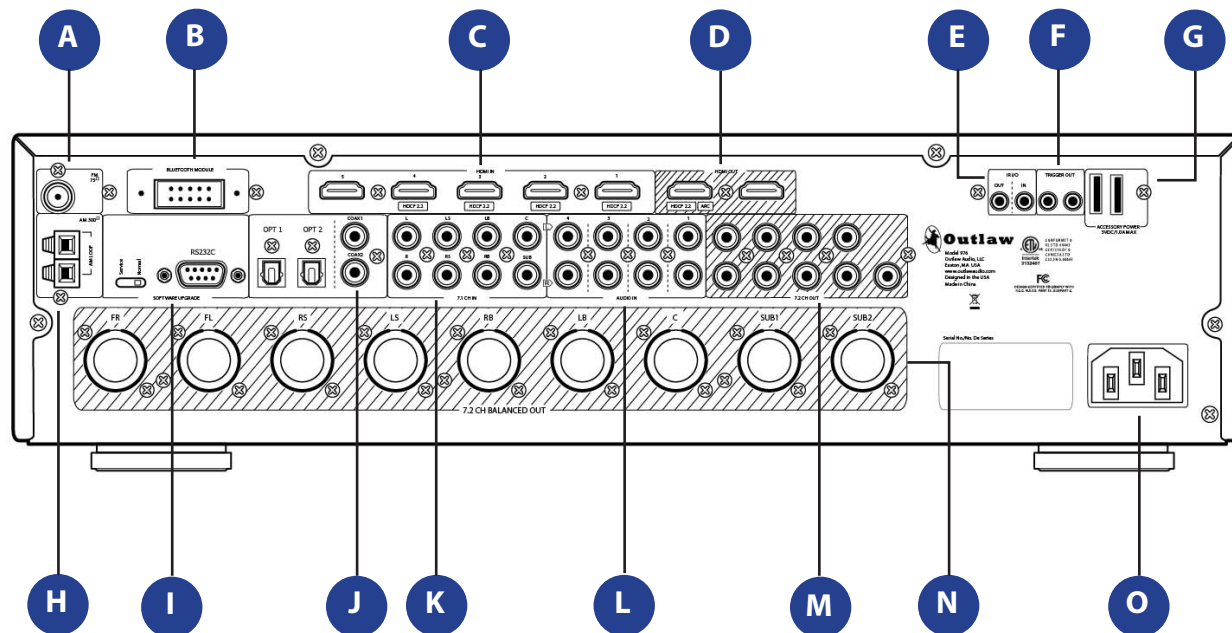

A. FM Antenna terminal (see page 20)

Use to connect the supplied FM antenna or an external 75Ω antenna.

B. Bluetooth Module Receptacle (see page 20)

This port is where you plug in an optional Bluetooth Receiver. This will allow a wireless connection from any bluetooth source such as a smartphone.

C. HDMI Input jacks (see page 19)

These jacks provide the best possible audio and video connection to sources, including support for the latest high-resolution formats. HDMI Inputs 1-4 are HDMI 2.0b and HDCP 2.2 compliant. As such, these inputs are capable of accepting 4K, HDR-10, and Dolby Vision video.

D. HDMI Output jacks (see page 20)

Use these outputs to connect to your video displays. The HDMI output jack labeled HDMI OUT 1 ARC can also carry audio back from your TV set into the 976. HDMI OUT 1 is the primary output and is 4K/HDR/Dolby Vision/ARC compatible. HDMI OUT 2 is the secondary output.

E. IR I/O jacks (see page 21)

When your Model 976 is hidden behind doors that prevent the remote control from “seeing” the front panel IR sensor, you may connect an optional external IR sensor to this 3.5mm mini-plug. To send the IR signal to another product in a “daisy chain” configuration, connect the IR Out jack to another product with a compatible IR system.

F. DC Trigger Outputs (see page 21)

These 3.5mm mono mini-jacks provide a continuous 5VDC signal that may be used to control optional external amplifiers from Outlaw and other brands, as well as other compatible accessories.

G. Accessory Power Ports (see page 20)

Use these USB ports to provide 5V power to accessories such as phones, tablets, or external hard drives. Do not connect a data source to these ports.

H. AM Antenna terminal (see page 20)

Connect the supplied AM loop antenna to these inputs.

I. RS-232C control & switch

The RS-232C port is used to install firmware updates only. The switch is used to set the mode for the RS-232C connection. For normal operation, it should be left in the NORMAL position.

J. Digital Optical & Coax Input jacks (see pages 17-18)

Optical and coaxial digital audio inputs. Connect the digital audio outputs from audio sources such as a CD/SACD player, DVD player, or Blu-ray Disc player.

K. 7.1 Analog Input jacks (see pages 17-18)

Eight-channel analog audio input. Connect the multichannel analog audio outputs of sources such as DVD-Audio/SACD players.

L. Analog Audio Input jacks (see pages 17-18)

Two-channel analog audio inputs. Connect the line-level analog audio outputs of sources such as a CD player or turntable with phono pre-amplifier.

M. 7.2 RCA Output connections (see page 21)

Unbalanced pre-amplifier outputs for connection to amplifier(s) and subwoofer(s).

N. 7.2 XLR Output connections (see page 21)

Balanced pre-amplifier outputs for connection to amplifier(s) and subwoofer(s).

O. AC Input (see page 22)

Use to connect the supplied AC power cord (see Precautions on page 3).

Remote Control

Remote Control Power/Input/Numeric Controls

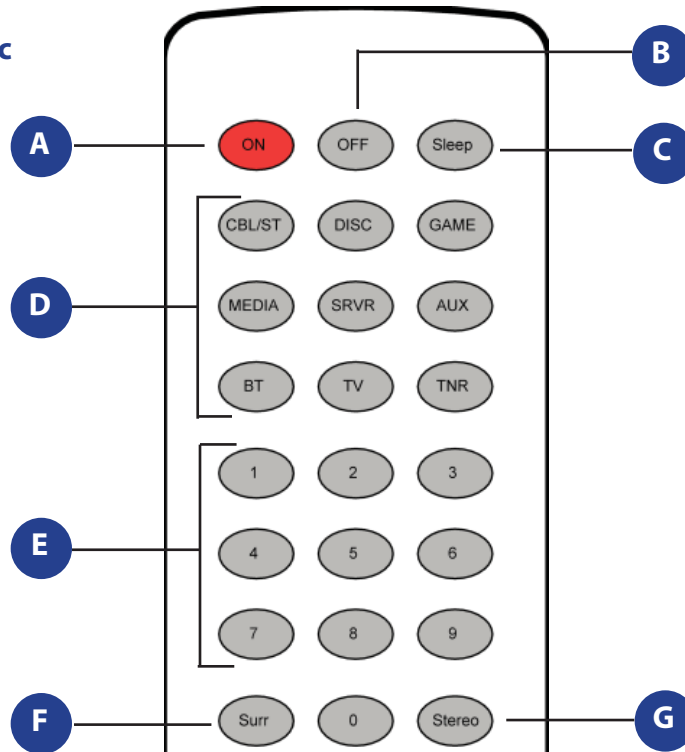

For your convenience, the Model 976 comes with a remote control.

A. Power On (Page 33)

Press this button to bring the Model 976 out of standby mode.

B. Power Off (Page 33)

Press this button to place the Model 976 in standby mode.

C. Sleep (Page 38)

Press this button to activate the sleep function, which turns the Model 976 off after a user-selectable amount of time.

D. Source/Input Selectors (Page 33)

Press the button corresponding to the name of the input you wish to listen to. Options include Cable/Sat (CBL/ST), Disc, Game, Media, Server (SRVR), Aux, Bluetooth (BT), TV, and Tuner (TNR).

E. Numeric Keypad (0-9) (Page 40)

Press these buttons to enter numbers for different functions such as direct input of station frequencies and direct access to preset stations for the tuner.

F. Surr (Pages 14 and 34-35)

Press this button to cycle through the available surround processing modes. The first press will display the current mode.

G. Stereo (Page 35)

Press this button to select stereo mode instead of surround processing modes.

H. Menu (Pages 23)

Press this button to access the Model 976's setup menu.

I. Cursor Control (Pages 23, 26, and 37)

These buttons control the cursor when navigating the setup menus. In addition, the Up and Down buttons cycle through the radio preset stations.

J. Sync (Page 36)

This button provides access to the AV sync control for the active input.

K. Volume Up/Down (Page 34)

Press these buttons to raise or lower the volume.

L. Night Mode (Page 38)

Press this button to enable or disable Night Mode.

M. EQ (Page 38)

Press this button to engage and disengage the EQ.

N. Tone (Page 36)

Press this button to adjust the bass and treble settings.

O. Direct Mode (Page 40)

This button starts the process of selecting a broadcast station directly. Within five seconds of pressing the button, key in a broadcast frequency using the numeric pad (E).

P. Exit (Page 23)

Press this button to exit the Model 976's setup menu.

Q. Enter (Page 23)

When navigating the setup menu, pressing this button will access sub-menus or select highlighted options.

R. Test (Page 37)

Press this button to access audio test tones and adjust channel levels.

S. Mute On/Off (Page 34)

Press this button to mute the speaker outputs. The front panel mute button's blue LED will be on when Mute is engaged.

T. Tuner Scan Up/Down (Page 39)

When the tuner is in use, press these buttons to go to the next higher or lower broadcast frequency.

Remote Control Cursor/Volume/Direct Access Controls

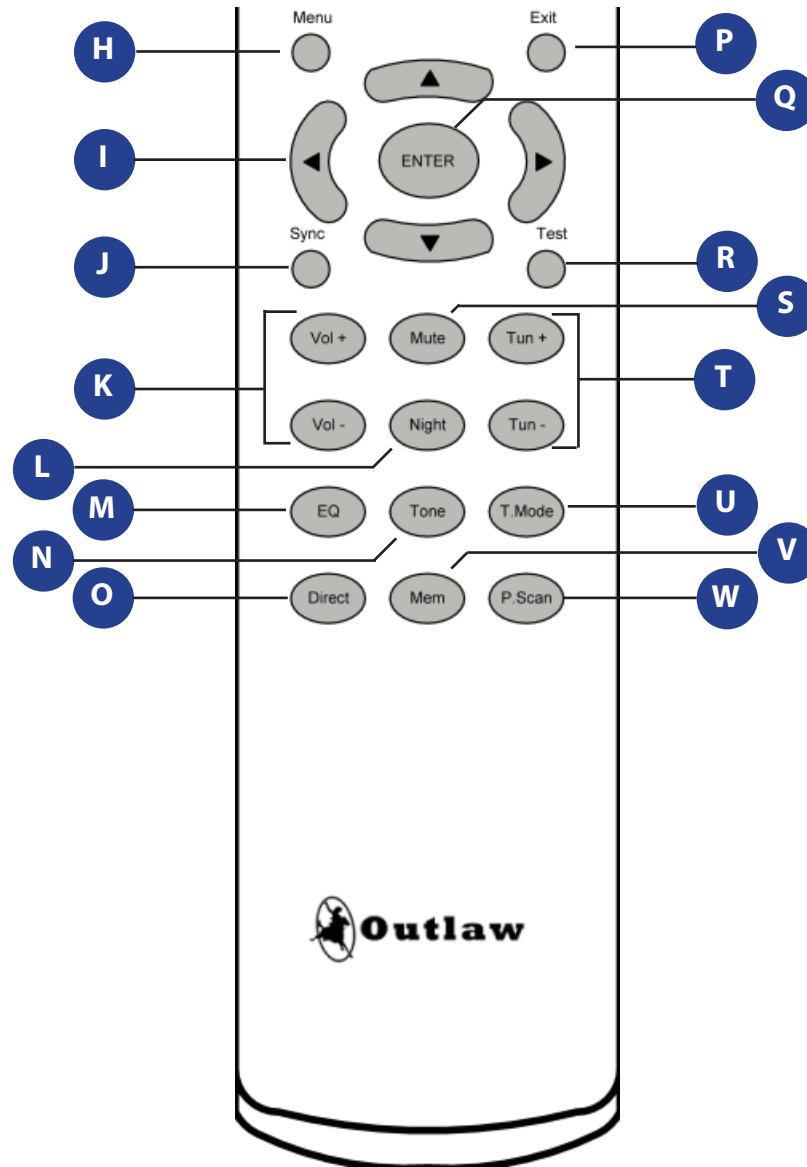

U. Tuner Mode (Page 41)

This button selects either the "FM Stereo" or "FM Mono" tuner mode.

V. Memory (Page 40)

Press this button to begin the process of entering a radio station's frequency into the tuner memory for quick recall.

W. Preset Scan (Page 40)

Press these buttons to scan through the list of radio station frequencies that you have programmed into the Model 976.

Loading Batteries

The bottom end cap of the Model 976 remote is a hinged lid on the battery compartment. Slide this end cap toward the back of the remote and let the end cap swing open to reveal slots for (2) AAA batteries. Load the batteries with exposed ends matching the "+" and "-" marks on the inside of the end cap. Slide the battery cover door back into place. The door should click when the cover is locked. Test the unit by pressing any key. If the batteries are inserted correctly, the backlight will illuminate all of the keys.

Note: The batteries will usually last about six months under normal use. When batteries need replacement, the remote will blink twice with every key press. Simply replace both batteries and the remote control will be restored to its full functionality.

Front Panel Display

Model 976 Front Panel Display

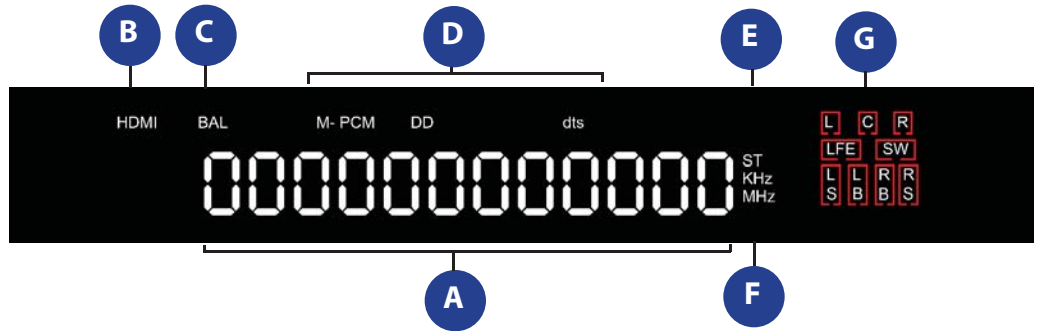

Model 976 Channel Icon Display

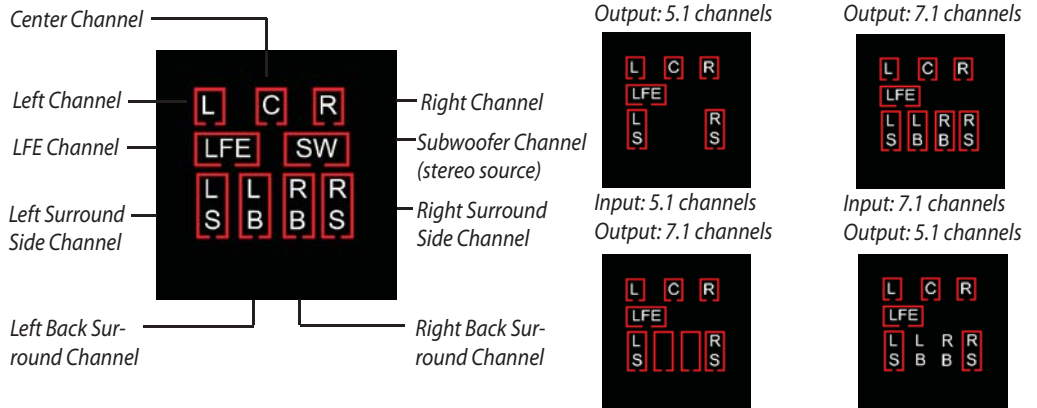

The front panel display provides information and visual feedback whenever the Model 975 is turned on. A brief explanation of the display's readouts is shown below.

For full access to setup and all functions, you will have to use the on-screen display (OSD), which can only be seen on a video monitor connected to the Model 976 through HDMI Out 1.

- A. Alphanumeric Readout**
Displays a range of information, including the selected input (page 33), audio format and surround mode (pages 34), volume and other adjustment settings (pages 34-38), and tuner preset and/or frequency (pages 39-41). Information will scroll across the display if necessary.
- B. HDMI indicator** (see pages 26 and 33)
Lights with an HDMI source is in use.
- C. BAL indicator** (see page 37)
Lights when the channel level of one or more speakers has been adjusted from the default setting (0 dB).
- D. Surround Mode indicators** (see page 34)
Lights if the audio signal of the selected source is stereo PCM (PCM), multichannel PCM (M-PCM), Dolby Digital (DD) or DTS (dts). The DD and dts indicators also appear if PLII/IIx or Neo6 processing is in use.

- E. Stereo indicator**
Lights when the audio signal of the selected source is a stereo signal.
- F. Tuner Frequency Range indicator** (see pages 39-41)
Lights when the tuner is the input source and either the AM (kHz) or FM (MHz) band is selected.
- G. Channel Icons**
Indicates the audio channels present in the source signal (one, two or multi-channels) as well as the output channels based on your speaker configuration and surround format chosen. See examples above.

Note: The channel icon display graphically represents the active audio inputs and outputs of the Model 976. Illuminated letters indicate the audio channel(s) being received from the selected source, while the illuminated red boxes show the output mix being sent to the speakers. The source is either passed through unchanged (box around the letter), upmixed using a surround processing mode (empty box), or downmixed (letter without a box) depending on the system configuration and active surround processing mode.

5.1 Multichannel Digital Audio



7.1 Multichannel Digital Audio



With the exception of immersive audio formats such as Dolby Atmos, the Model 976 supports almost any audio format out there. These include lossy and lossless digital audio formats used by Blu-ray and Internet video streaming devices; the older digital audio formats used by DVD and digital TV; and more generic audio data such as analog, stereo PCM, and multichannel PCM. It also includes additional processing modes that can be used with certain of those formats. To assist in understanding the supported input formats and processing modes of the Model 976, we are devoting one section of this guide to two separate subjects: audio formats (the incoming audio data), and listening modes (the decoding and processing schemes which can be applied to that audio data).

Analog Stereo and PCM Stereo

These two sources are treated the same way by the Model 976. The first is analog stereo connections, similar to what you might find from a VCR or some older game consoles (Nintendo Wii, for example). The second is digital connections with stereo PCM signals, including sources such as CDs and some digital cable channels. The first case (stereo analog) is converted to stereo PCM by an ADC, so it may be handled by (DSP). The PCM signals are affected by the DSP (and therefore the 976’s processing, such as EQ and the application of additional listening modes) and then converted to analog to send out to your power amplifier.

Dolby Digital

Dolby Digital was first called AC-3 when it appeared in the 1990s on LaserDisc, and it was the first format to provide true multichannel digital audio for consumer use. When the DVD specifications were established a few years later, Dolby Digital (often abbreviated “DD”) was included as the default audio format. Dolby Digital offers up to five discrete full-range channels (left, right, center, left surround, and right surround) and a low frequency effects (LFE) channel; these six channels are often referred to as “5.1” because the LFE channel is limited to low frequency data only. To allow these tracks to fit on media such as DVD and be passed across digital connections

originally designed for just two audio channels, lossy compression is used to compact the original data into a smaller size, allowing the audio tracks to use much less space than would be required for an uncompressed multichannel track.

Dolby Digital soundtracks are not required to use all six channels, so you will often encounter Dolby Digital 2.0 tracks (stereo) or even Dolby Digital mono tracks. Those mono tracks sometimes include two channels (left and right) with identical data in both (or “Dolby Digital 2.0 Mono”), but other times they contain a single channel (“Dolby Digital 1.0”).

Dolby Digital Plus

Dolby Labs developed a successor to Dolby Digital for use with Blu-ray and Internet streaming services. This audio format is called Dolby Digital Plus (DD+). Dolby Digital Plus offers up to 7.1 discrete channels (extensible to 16 channels); it’s not limited to 5.1 discrete channels as its predecessor was. It also employs more powerful lossy compression, enabling both lower bitrates and higher quality at higher bitrates.

Dolby TrueHD

Dolby TrueHD was developed for use with HD disc formats such as Blu-ray Disc. The technology is an extension of Meridian Lossless

7.1 Multichannel High Resolution Lossless Digital Audio



Packing (MLP), the lossless audio compression format employed on DVD-Audio. Since the compression used does not discard any data, a TrueHD track preserves the original integrity of the uncompressed master.

DTS

DTS is an alternative to Dolby Digital that shares the same basic concept: six channels of audio, compacted using a lossy compression algorithm to save space. DTS uses an algorithm that is not as efficient as Dolby Digital and therefore not as heavily compressed, which many people believe allows it to sound better.

DTS-HD High Resolution

DTS responded to Dolby Digital Plus with DTS-HD High Resolution. DTS-HD High Resolution is an extension to DTS 96/24 that allows higher bitrates, but it still employs lossy compression. Like DD+, DTS-HD HR supports 7.1 channels, may be included on both Blu-ray and HD-DVD, and can only be transmitted via HDMI v1.3 or higher.

DTS-HD Master Audio

Despite the similarities in name, DTS-HD Master Audio is a completely separate audio format from DTS-HD High Resolution. Like Dolby TrueHD, DTS-HD MA employs lossless compression to provide a format that offers the sound quality of an uncompressed PCM track while offering a way to use less disc space. DTS-HD Master Audio also supports 7.1 channels.

Multichannel PCM

HDMI allows sources to output multichannel PCM because the connection can support the greater volume of data required to transmit up to eight channels of uncompressed digital audio. A multichannel PCM signal may be as delivered directly on a Blu-ray Disc, or as derived from any compressed audio bitstream the player can decode (including the formats listed above).

DSD

Around the time that the DVD-Audio format was released as a prospective successor to CD, Sony introduced the SACD format for both stereo and multichannel audio. Both disc formats offer digital audio quality superior to CD audio as well as support for 5.1 audio. Where DVD-Audio used a lossless compression technology to package PCM (pulse-code modulation) audio, SACD used an encoding technology called DSD that uses pulse-density modulation. SACD players with an HDMI v1.2 or higher output may output a native DSD bitstream. The Model 976 cannot decode a DSD signal; your player will need to output PCM.

Note: Not all disc players support SACD or DVD-Audio playback. See your player's specifications.

Dolby Pro Logic II/IIx Movie

This mode takes two-channel movie and TV content, such as Dolby Digital 2.0 DVDs, most TV shows, Netflix programs, etc., and converts them to 5.1 (Pro Logic II) or 7.1 (Pro Logic IIx). The parameters in this mode are non-adjustable. You can leave this mode on for all two-channel TV and movie material. It's comparable to DTS NEO:6 Cinema, so you should try both and see which one you like better.

Dolby Pro Logic II/IIx Music

This mode converts two-channel music from analog or digital sources to 5.1 or 7.1. It offers three adjustable parameters: Center Width, Dimension and Panorama. For explanations of these, see page 32. It's roughly comparable to DTS NEO:6 Music mode; we recommend you use whichever mode you like best. You may find one or the other works better for certain types of music.

Dolby Pro Logic II/IIx Game

The PLII/IIx Game mode is optimized for use with video games that have 2.0-channel sound, and especially for use with games that are Pro Logic II-encoded.

DTS NEO:6 Cinema

NEO:6 Cinema converts any two-channel movie or TV content into 5.1, 6.1 or 7.1. It works great with most TV shows, Netflix programs, etc., and you can leave it on for all two-channel TV and movie material. It's similar in function to Dolby Pro Logic II/IIx Movie mode, so you can compare the two and use whichever one you prefer.

DTS NEO:6 Music

NEO:6 Music is tuned to work well with any two-channel music source, whether analog or digital. Compare it with Dolby Pro Logic II/IIx Music mode and use the technology that sounds best to you.

All Channel Stereo

This is the only non-licensed surround mode we chose to include in the Model 976, and we included it for a very good reason: It's the perfect mode for parties. The same sound comes from the front and rear speakers—it's not matrix-decoded as it is with PLII/IIx and NEO:6—so the sound spreads nicely around the room and all your guests can hear the music. Some people like it for regular music listening, too.

Typical 5.1 Surround Speaker Placement

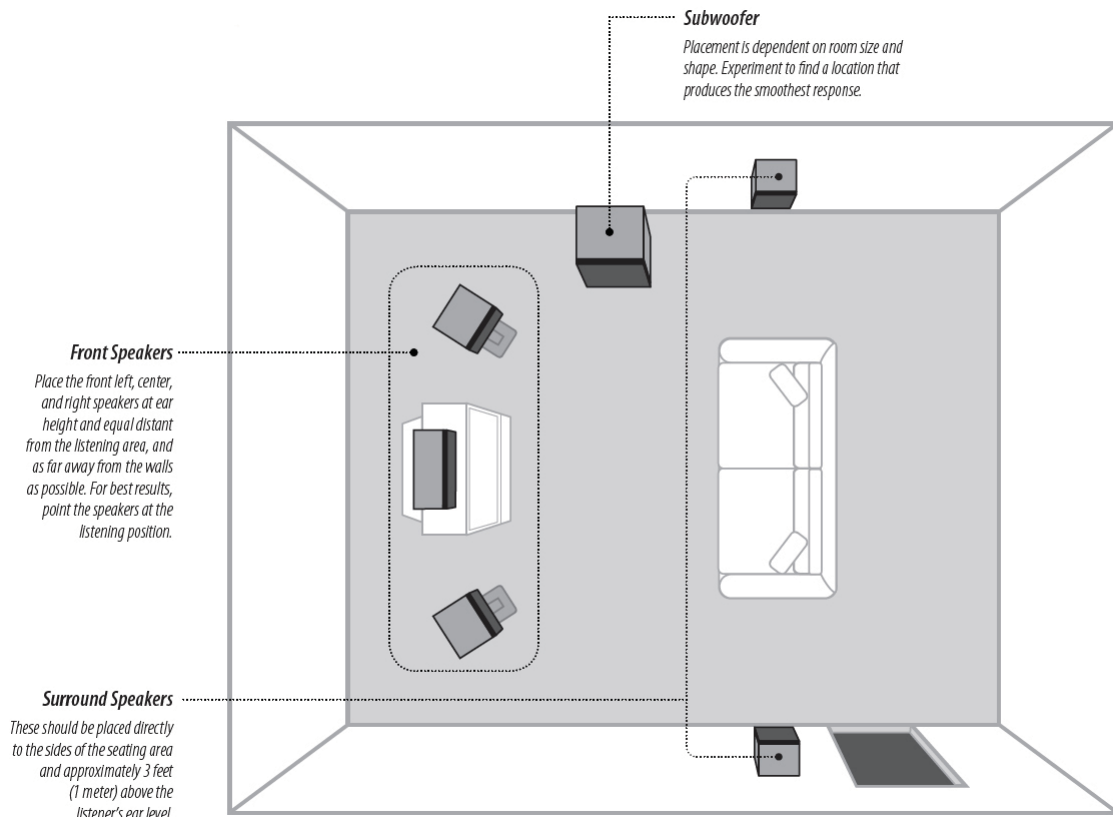

Before we explain how to configure your Model 976 for your speaker system, let's make sure your speakers are already set up to get the best possible performance. Even if you're an experienced home theater enthusiast, you may pick up a useful tip here. After all, the Outlaws have been designing and working with home theater systems since 1989! We've heard everything, read everything, tried everything.

The best speaker placement for your particular room will depend on its size, furnishings, seating arrangement, the acoustical properties of the space, including wall type, coverings, and various other factors.

Due to the complex nature of these variables it is impossible to recommend any one-size-fits-all placement. You may well have to experiment with various placement options to determine the best configuration for your specific situation. Please note that, the configuration and placement of your speakers is critical for creating the best possible surround sound playback.

When connecting any speakers, be sure to read the instruction manuals that came with the product and check your power amplifier's instruction manual for proper hook-up of the loudspeakers.

Front left, center and right speakers

- These speakers should be placed at the same relative height from the floor and a similar distance from any walls. Most speakers sound best when located with the tweeter at ear height when you're seated. Typically, the further away from the walls the speakers are, the better they will sound.
- Ensure that the speakers are aimed at the listener's ears within your chosen seating position.

Surround left and right speakers

- Place these speakers so that their height is approximately 3 feet (1 meter) higher than that of the listener's ears if feasible.

Note on dipole surround loudspeakers:

Most dipole surround speakers have an arrow which indicates their proper orientation relative to your video display/screen. Dipoles placed on side walls should have the arrows pointing forward. Dipoles placed on a rear or back wall should have the arrows pointing towards each other to achieve the correct acoustical image in the room.

7.1 Surround Speaker Placement Options

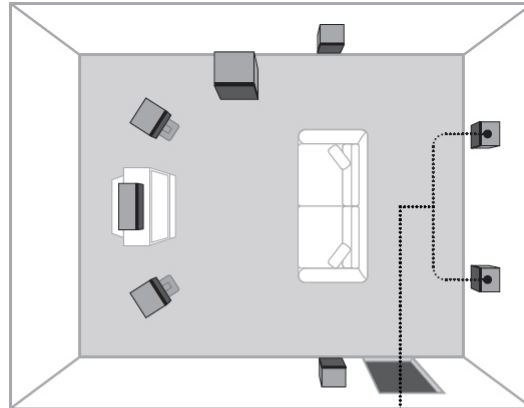

Surround Back Speakers

If you are using surround back speakers, place them approximately 3 feet (1 meter) above the listener's ear level and 30° off the center axis.

Subwoofer(s)

Using two or four matching subwoofers results in much smoother bass response across a large seating area. The subwoofers can either be placed in the corners of the room, or in the middle of the walls.

Subwoofer Placement Options

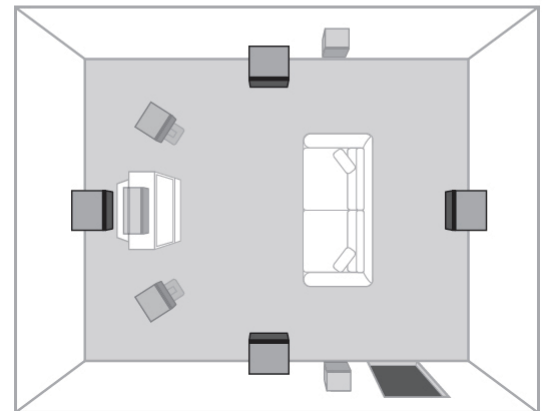
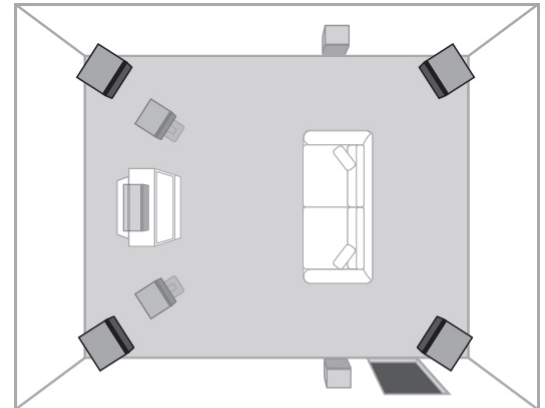

Surround back left and right speakers

- These speakers are required for 7.1 audio playback. Place them behind the listener so that the angle between each speaker and the listener is approximately 30 degrees.
- Place these speakers so that their height is either at ear level or 3 feet (1 meter) higher than that of the listener's ears.

Subwoofer

Subwoofer placement can frequently be a trial-and-error affair as bass energy sets up "standing waves" in most every room. These standing waves can cause areas with too much bass, areas with too little bass, and areas in between. You may have to move the subwoofer and or the prime listening area to improve the bass response. Be aware that every surface you place the woofer close to (one wall, floor, two walls in a corner) will increase the overall apparent bass in the room. But this can potentially lead to boomy and muddy sounding bass.

Recent research has found that using two or four matching subwoofers results in much smoother bass response across a large seating area. If you want to make the bass sound good for several listeners (and not just you), this is worth exploring. You can place the subwoofers in the corners of the room, or in the middle of the walls. You can use Y-adapters to connect each of the Model 976's subwoofer outputs to multiple subwoofers if more than 2 subs are needed.

Connecting Your Model 976

There are many possible ways to connect a particular device. Use the diagrams and notes on the following pages as a guideline. The information in this section contains some of the more common situations you might encounter in your system. Always consult the owner's manual that came with the component you are connecting for more information about procedures, warnings, and options for the source component's connections.

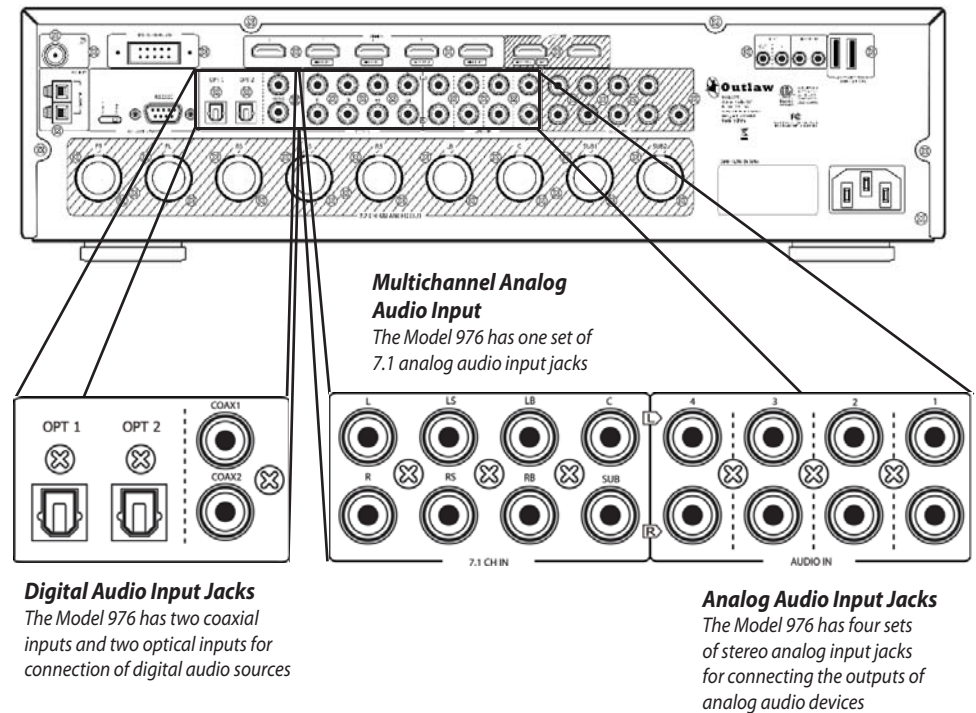

Chapter 2 Contents

- 17 Connecting Audio
- 19 Connecting Video
- 20 Accessory and Antenna Connections
- 21 External Amplifier Connections
- 21 Power & IR Control Connections
- 22 Power Connection

Before you make any connections to your new Model 976, please observe the following precautions:

- Do not plug the power cord into your Model 976 until all other connections have been made.
- Always refer to the instructions that came with the component that you are connecting for specific procedures, warnings and options.
- For analog audio source device connections, the red input jacks (R) are used for the right channel and white input jacks (L) are used for the left channel.
- Make sure to insert all plugs and connectors securely. Improper connections can result in noise, poor performance, or damage to the equipment.
- Do not bundle audio/video connection cables with power cords and speaker cables. Doing so may adversely affect the picture and sound quality. For example, run all the power cords down one side of the cabinet, all the signal cords down the other side, and the speaker wires down the center.

IMPORTANT NOTE

We strongly recommend that before you connect any loudspeakers to your amplifiers, you complete all needed connections and setup procedures to your Model 976 as outlined below. This will reduce the chance that a misconnection or other error will produce audio output that might damage your speakers or other components.

Note about HDMI Connectivity

Whenever two or more devices are connected using HDMI cables, during the initial power on cycle there is an initial "handshake" communication between them. This takes place only during the first three to five seconds after powering on the devices. If this handshake is successful, you will achieve normal Video and Audio. However, sometimes there can be handshake issues simply due to a poor connection. HDMI handshake issues can affect video and audio, as both are transmitted through these cables. Some examples are: Flashing picture, no picture, audio popping or crackling sound, snow on image, or no audio. If you experience any of these, please refer to the troubleshooting info on page 44.

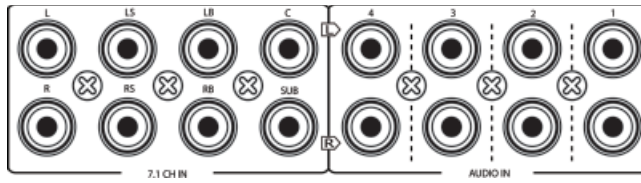
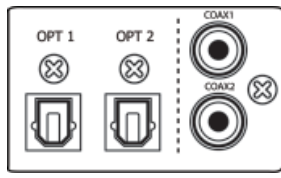

Given the wide variety of components that can be connected to your Model 976, there are numerous ways to assemble your system. To help, we have provided a chart (page 46) to record the components connected to your unit, as well as which type of input (HDMI, analog, coaxial, etc.) is used. Keep this chart for future reference.

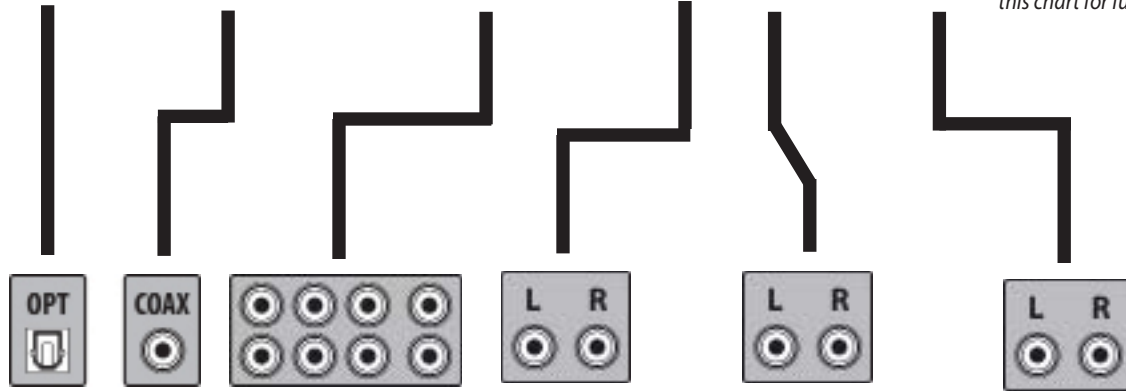

Digital Connectors

If your component can output digital audio, it will have either one or both of the connectors shown above.

Multichannel Analog

Some DVD, DVD-Audio, SACD, or BD players will offer multichannel analog with either 5.1 or 7.1 analog output jacks.

Analog Connectors

If your component uses analog audio, it will have either stereo RCA jacks as shown above or a mini stereo jack (small headphone jack).

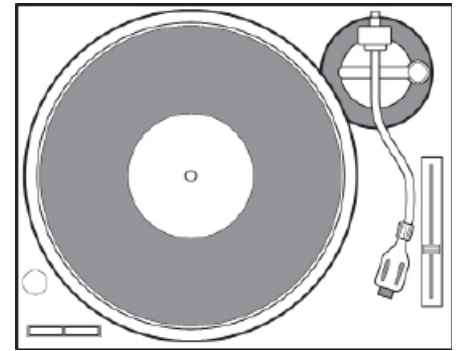
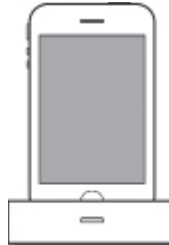

While the typical home theater today is dominated by audio/video sources that use HDMI to output digital signals for both video and audio, there may still be some legacy sources that use either analog audio, coaxial digital audio, or optical digital audio.

Stereo Analog

The Model 976 includes four sets of stereo analog audio inputs. These may be used with legacy audio sources such as turntables, cassette decks, and any other source that only provide left/right analog audio outputs. Connect the left and right analog outputs to one of the four sets of inputs and note which analog input the device was connected to in the Input Summary Sheet on page 46.

Note: Record Turntables

The Model 976 does not incorporate a built-in phono preamp, so if you want to connect a turntable, you will have to provide a phono preamp to connect between the turntable and the Model 976. Connect the L and R channel outputs of the phono preamp

to the Aux stereo audio input jacks on the Model 976. Other analog audio input jacks may be used if the Aux jacks are already in use. Connect the L and R channel outputs (plus the ground wire, if needed) to the inputs of the phono preamp.

Multichannel Analog Audio

The Model 976 includes a 7.1 channel audio input that can be used to connect to a legacy audio source such as a DVD-Audio player, SACD player, or even a DVD, Blu-ray Disc, or UHD Blu-ray Disc player with multichannel analog audio outputs. If the source includes a 5.1 channel audio output (such as DVD-Audio or SACD), use the Left, Right, Left Surround, Right Surround, Center, and Subwoofer inputs but not the Left Back and Right Back inputs. Note which device has been connected to this input in the Input Summary Sheet on page 46.

Digital

If your device offers digital outputs, connect it to one of the coaxial (Coax 1 or 2) or optical (Opt 1 or 2) input jacks on the Model 976, depending on the type of connector used by your source. Later, you will configure the Model 976 to use the specific input that you have chosen. For now, note which digital input you connected to on your system chart.

Connecting Video

Blu-ray Disc Player

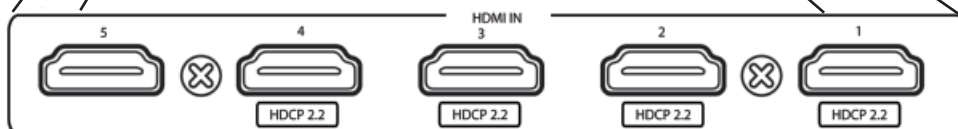
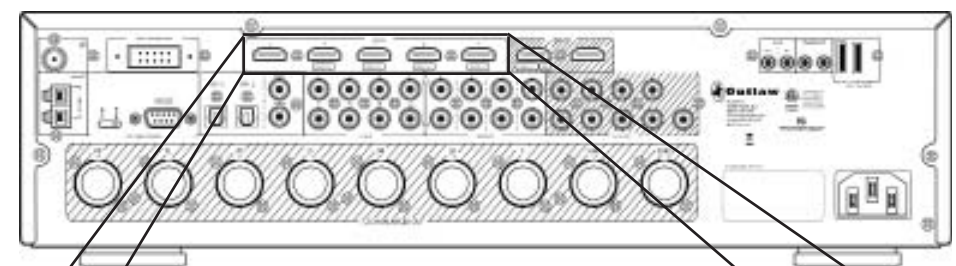

HDMI Jacks

The Model 976 has five rear HDMI input jacks and one front HDMI input jack for connecting to the video and audio outputs of your video devices. Note that inputs HDMI1 through HDMI4 support 4K UHD video and HDR/Dolby Vision.

HDMI Output Jacks - 4K UHD

For sources with HDMI output that offer HD resolution or 4K UHD resolution, connect to any of the first four HDMI inputs on the rear panel of the Model 976



HDMI Output Jacks

For sources with HDMI output that offer HD resolution only, you may use any of the six HDMI input jacks, including HDMI IN 6 on the front panel near the volume control.

The last 15 years have seen a radical shift in how video signals pass between devices in a home theater. The Model 976 reflects this change. Before making connections to any video devices, it will help to understand how the Model 976 routes the video portion of the signal through its video section.

For UHD signals, the Model 976 will pass HDR and Dolby Vision signals.

- All HDMI inputs can be assigned to the CBL/SAT, DISC, GAME, MEDIA, SERVER, and AUX inputs.
- The audio selections are fixed for the BLUETOOTH (BT) and TUNER (TNR) inputs to the bluetooth and tuner respectively. For video, you may select HDMI IN 1-6.
- The video selection for TV is fixed to NONE. For audio, you may select coax, optical, HDMI ARC, analog stereo, and 7.1 analog inputs.

HDMI

The Model 976 includes five rear HDMI inputs and one front HDMI input. Inputs HDMI1 through HDMI4 may be used with UHD 4K video sources such as UHD Blu-ray Disc players, streaming media players, and cable/satellite receivers that support 4K video and HDR (high dynamic range) video output. Inputs, HDMI5 and HDMI6 (front input) support up to 1080p HD video.

Connect the HDMI output of the source device to one of the HDMI inputs on the model 976. This is the only connection you need to make from the source device to the Model 976. Note which HDMI input you connected on your system chart, because you will have to configure the input later through the on-screen menu. For UHD 4K sources, verify that the HDMI cables are rated for 4K HDR video.

In some rare cases, a user may wish to connect an older video source that includes DVI output for video alongside separate audio output. In those cases, a DVI-to-HDMI cable may be used to connect the DVI output to one of the HDMI inputs. Audio must be connected separately; see the Analog and Digital Audio Inputs section for that connection. Note that the DVI source must support HDCP to allow the Model 976 to accept the digital video signal.

Video Display

Accessory and Antenna Connections

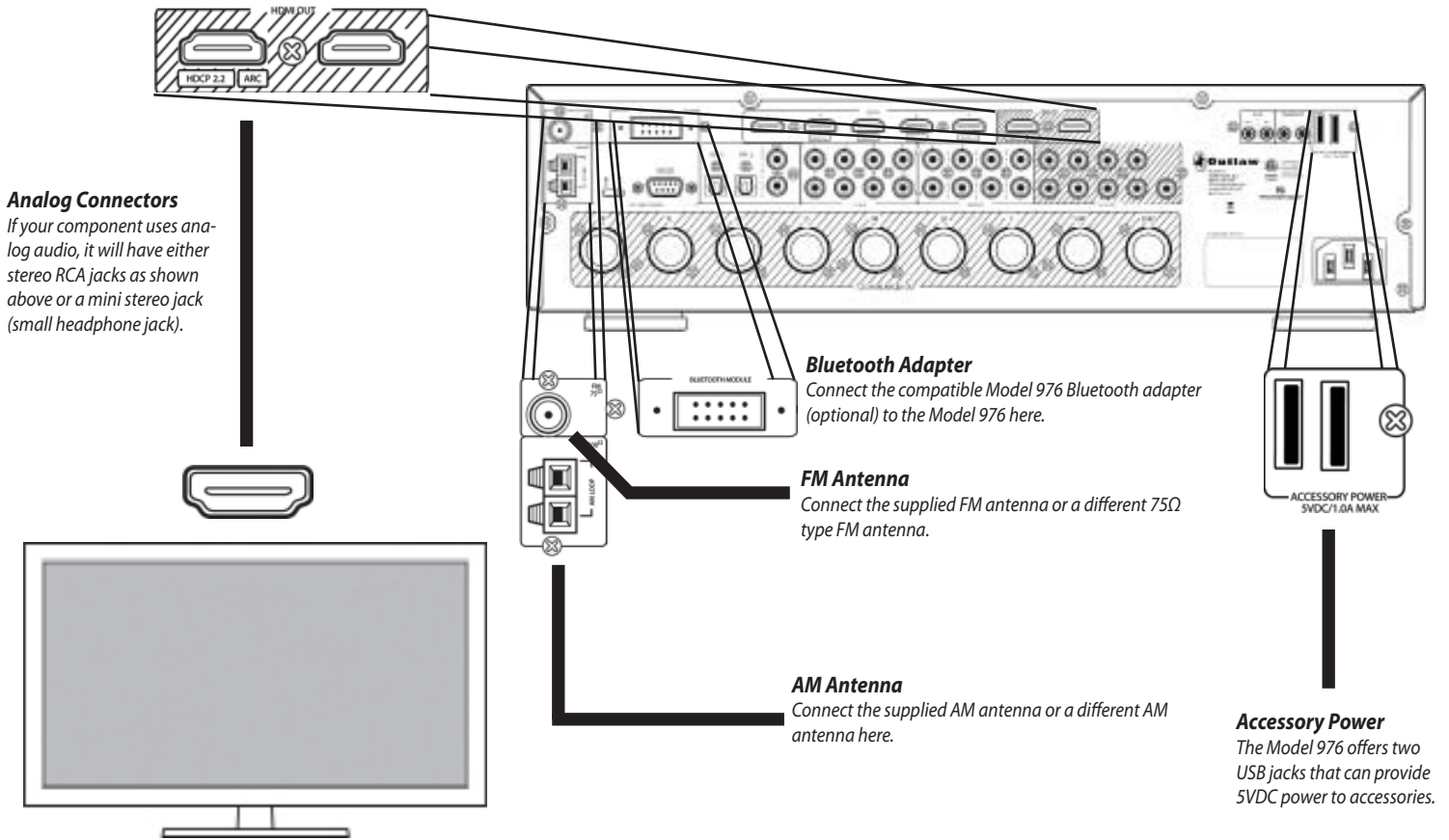

A video display device such as a flat-panel TV or a video projector can be connected to the Model 976 using the following methods.

Using two displays simultaneously will limit HDMI output 1 to 1080p

HDMI (UHD, ARC)

Connect the Model 976's HDMI Out 1 output to one of the video display's HDMI inputs. If you are using the ARC function, which feeds audio from the TV back into the Model 976, be sure to connect to the jack on the TV labeled HDMI/ARC. If you are connecting any UHD sources to the Model 976, be sure that the input in the TV is rated for HDMI 2.0 and HDCP 2.2.

HDMI

If you want to connect a second display to the Model 976, the HDMI Out 2 output can be connected to an HDMI input. The on-screen menu and UHD sources will not be available, but any other sources will be passed through to this display.

Accessory Power

Some devices in your system may be powered from a USB wall adapter. Examples include Google's Chromecast and Amazon.com's FireStick. If you have any of these devices, you may connect their USB power cord to one of the two Accessory Power USB ports found above the AC power cord on the rear panel of the Model 976.

Bluetooth

The Model 976 integrates with a compatible Bluetooth receiver, which may be connected to the Bluetooth Module input on the rear panel of the Model 976. Install this optional adapter to allow streaming of audio from a smartphone or tablet to the Model 976.

Note: Only connect or remove the Bluetooth receiver when the Model 976 is turned off.

FM Antenna

Connect the supplied FM antenna to the terminal labeled FM 75Ω. The Model 976's coaxial antenna terminal is designed for push-on type antenna cable connectors.

The supplied FM antenna is for indoor use only. For best signal reception you must fully extend the antenna. Experiment with the antenna's

position to obtain the strongest signal. You can attach it to a wall or other surface using push pins or similar apparatus.

If FM reception is poor with the supplied indoor antenna, the use of an amplified indoor or outdoor antenna is recommended.

NOTE: You can only connect a 75Ω type FM antenna to the Model 976. If you choose to use an antenna other than the one supplied, be sure to verify that it has the correct type of connector or that you obtain an appropriate adaptor.

If you use the same antenna for FM and TV signals, be sure to install a splitter to separate the two signals.

AM Antenna

Connect the AM antenna to the terminals labeled AM 300Ω on the rear panel of the Model 976. Press the spring-loaded levers to open the terminals, insert a wire into each terminal, then release the terminals. Give the antenna cables a very light pull to make sure they're connected.

If you experience reception problems, try turning the loop antenna in a different direction.

External Amplifier Connections

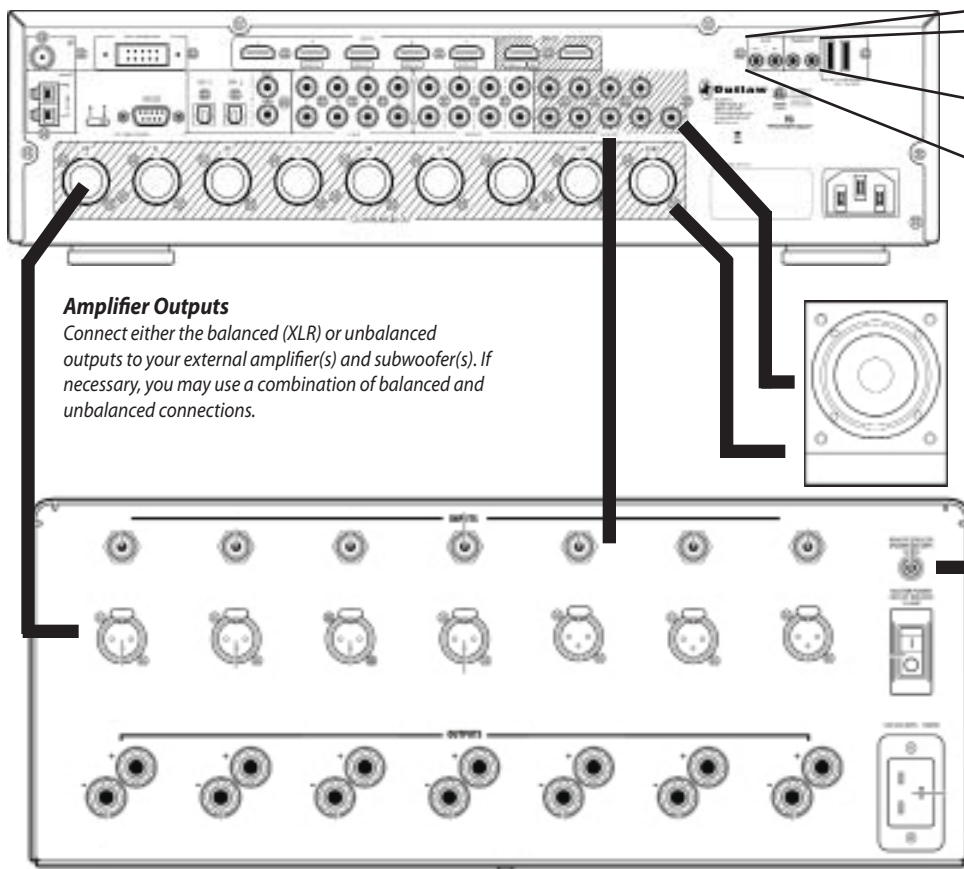

Amplifier Outputs

Connect either the balanced (XLR) or unbalanced outputs to your external amplifier(s) and subwoofer(s). If necessary, you may use a combination of balanced and unbalanced connections.

Power & IR Control Connections

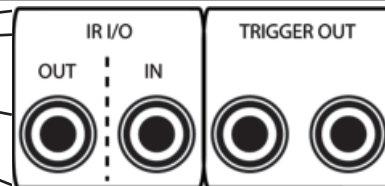

IR Input/Output

Use with an external IR remote sensor or RF-to-IR device.

Trigger Connections

Connect either Trigger 1 or Trigger 2 to a compatible DC trigger input on an amplifier or other device.

IMPORTANT NOTE: Before attempting to plug any jacks into any power amplifier verify that the power amplifier is turned off and/or disconnected from the AC mains. Failure to do so can potentially result in severe damage to your amplifier and loudspeakers.

The Model 976 is a Surround Sound Processor, and as such does not include amplifiers. It must be connected to one or more power amplifiers, such as Outlaw Audio's Model 7140 or Model 7700, so speakers can be connected to the amplifier(s). The Model 976 offers two types of pre-amplifier outputs that can be used to connect to those amplifiers.

Balanced (XLR) outputs

The 7.2 CH Balanced Outputs provide XLR balanced outputs for the front left, front right, center, left and right surround, left and right rear surround, and two subwoofer speakers. These XLR connectors provide a "balanced" connection that is better at rejecting ambient noise from sources such as power cables. If balanced (XLR) inputs are available on your amplifier(s) or subwoofer(s), these should be used to connect the Model 976 to those components.

Unbalanced (RCA) outputs

The 7.2 CH outputs provide unbalanced pre-amplifier outputs for the front left, front right, center, left and right side surround, left and right rear surround, and two subwoofer speakers. If your amplifier(s) or powered subwoofer(s) do not include balanced (XLR) inputs, these unbalanced outputs should be used to connect the Model 976.

When a powered subwoofer is used, connect the Subwoofer output jack to the Line Input jack on your subwoofer and follow any specific connection and/or configuration instructions supplied with the subwoofer. If your subwoofer is a passive speaker, connect one of the subwoofer output jacks on the Model 976 to the input of the amplifier used to power the subwoofer, and then connect the subwoofer speaker itself to the amplifier.

IR Input and Output

The Model 976 includes IR input and output ports that can be used with external IR remote sensors. To use the Model 976's remote when the Model 976 is concealed, connect an external IR sensor to the IR Input. A 3.5mm mono cable may be connected to the IR output to pass the IR signals through to an additional concealed component, such as a Blu-ray Disc player.

Power Control (Trigger) Connections

The Model 976 offers two 5VDC Trigger outputs that can be used to control compatible external components such as amplifiers, motorized projection screens, and blinds. When these outputs are enabled, the Model 976 applies power (5 volts DC) to these output jacks. By default, Trigger Out 1 is set to be activated with all inputs. This is the recommended trigger to use to activate amplifiers automatically.

Use a 3.5mm mono cable to connect the Trigger Out 1 or 2 of the Model 976 to a matching "Trigger" or "Control" input on the external component. Once the two units are connected, the external component will turn on when the Model 976 is on (if the active input is set to use that trigger) and off when the Model 976 is turned off. If the amplifier has a main power switch (often on the back), the power will probably have to be turned on at this switch before the DC trigger signal will work.

Power Connection

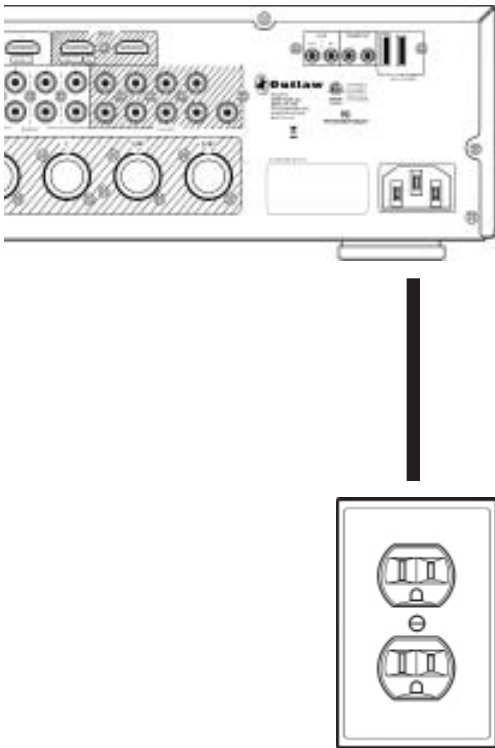

Insert the supplied power cord into the AC input of the rear panel of the preamp/processor. While we don't recommend substituting a different power cord without contacting Outlaw Audio first, replacements are available if needed.

CAUTION: Before you plug the power cord into an AC wall outlet, confirm that all connections to the Model 976 have been made correctly.

WARNING: Never disconnect the power cord from the Model 976 while the other end is plugged into an AC outlet. Doing so may cause an electric shock. Always connect power by plugging into the AC outlet last and disconnect by unplugging from the AC outlet first.

System Setup

At this point you should have made all the necessary physical connections between the Model 976 and your source equipment, amplifiers and speakers. All that remains is to properly configure the system to suit your speaker and amplifier configuration.

Although some of the Model 976's setup functions can be accessed directly through the front panel display and dedicated buttons on the remote control, it's probably easiest to perform the entire setup through the on-screen display (OSD), which can be seen on any video monitor connected to the Model 976's HDMI output. Note that the OSD functions only on the Model 976's HDMI output 1.

Menu Button

Press this button to see the Main Menu on your video display. Press it again to go back one level or to dismiss the menu completely.

Navigation Buttons

Press the Up and Down buttons to move up through the list of available menus or settings. Press the Left and Right buttons to adjust menu settings.

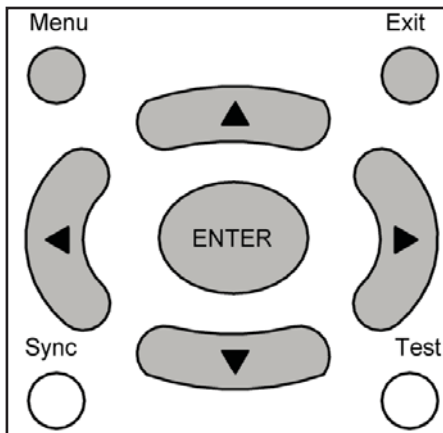

Exit Button

Press this button to immediately exit the system setup menus.

Enter Button

Press this button to make a selection from a highlighted menu item or parameter.

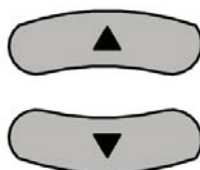

Navigation Buttons

Press the Up and Down buttons to move through the list of available menus.

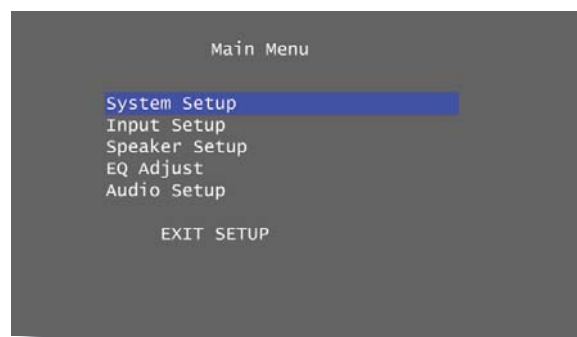

Enter Button

Press this button to select a system setup menu from the Main Menu.



Chapter 3 Contents

- 23 Menu Navigation
- 24 Main Menu
- 25 System Setup
- 26 Input Setup
- 27 Speaker Setup
- 31 EQ Adjust
- 32 Audio Setup

Before you begin, make certain that the AC power cord supplied with the Model 976 is firmly inserted into the socket on the unit's rear panel. Now plug the cord into an AC wall outlet or UL-approved power strip or surge protection device. The ring around the STANDBY button on the front panel will light up.

To turn the Model 976 on:

- Press the STANDBY button on the front panel or the POWER ON button on the remote to turn on the Model 976. The front panel display will illuminate and the ring around the STANDBY button will glow brighter.
- To get the rest of the system running, turn on the amplifier (if you're not using the Model 976's DC trigger to turn it on automatically), the source devices, and the video display.

We recommend that you perform the setup through the on-screen display (OSD), which can be seen on a display connected to the Model 976's HDMI Out 1 output.

Make sure the Model 976, amplifier(s), and display are turned on. Set the display to the HDMI input that is connected to HDMI Out 1; see the Input Summary Sheet on page 46 if necessary.

All selections are made using the same combination of buttons, as shown above. The MENU button on the remote and the OSD button on the front panel activate or cancel the on-screen menu.

The UP and DOWN arrow keys select a particular function or parameter from the on-screen display menu, while the LEFT and RIGHT arrow keys adjust whatever function or parameter you've just selected.

The ENTER button enters a highlighted menu or locks in adjustments that you've made.

Main Menu

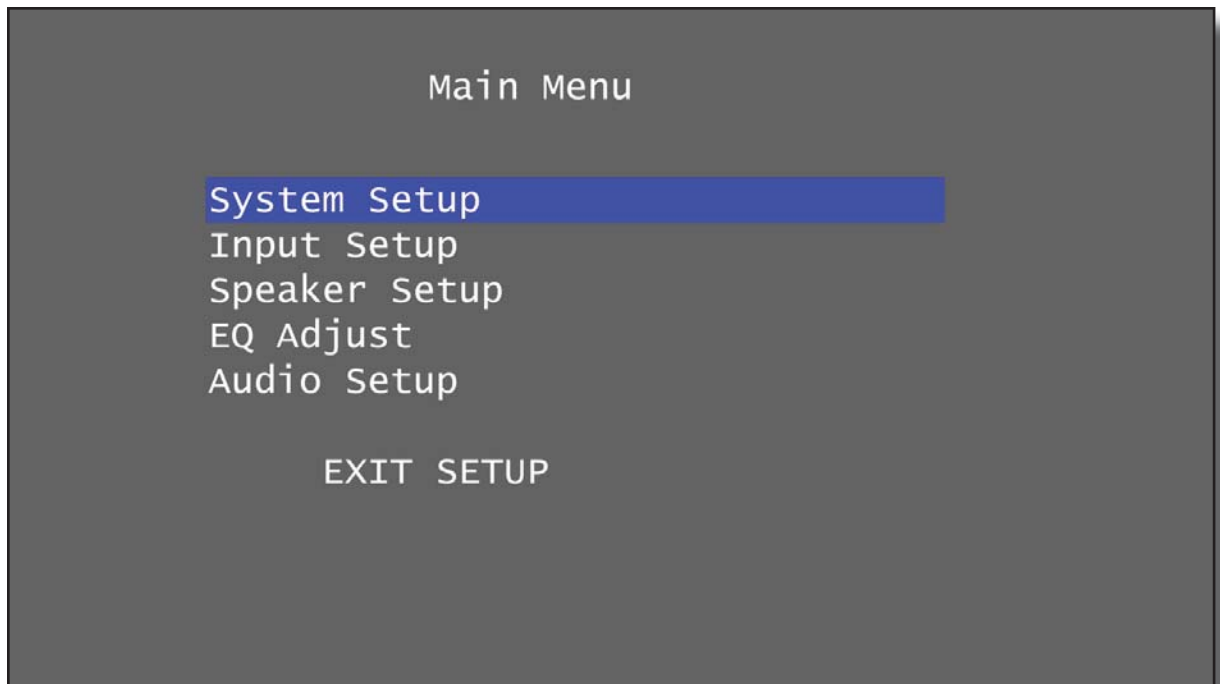

The Main Menu contains five menu categories and an option to exit the menu:

System Setup: Configure general system options such as front panel brightness and default start-up volume.

Input Setup: Configure each of the Model 976's inputs.

Speaker Setup: Configure the speakers that are connected to your Model 976.

EQ Adjust: Adjust the equalizers that are provided for each speaker channel.

Audio Setup: Configure treble and bass settings, Pro Logic II Music settings, DTS Neo:6 Music settings, and similar audio options.

Exit Setup: Exit the Main Menu.

Note: While the menu is active, all audio output is disabled and the incoming video is replaced with the menu.

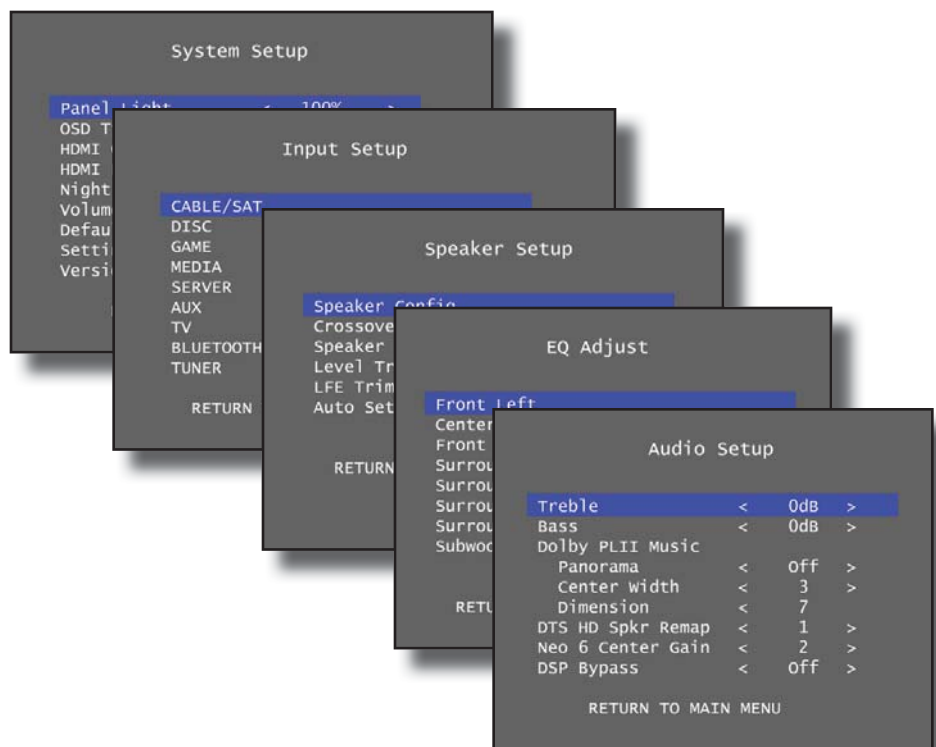

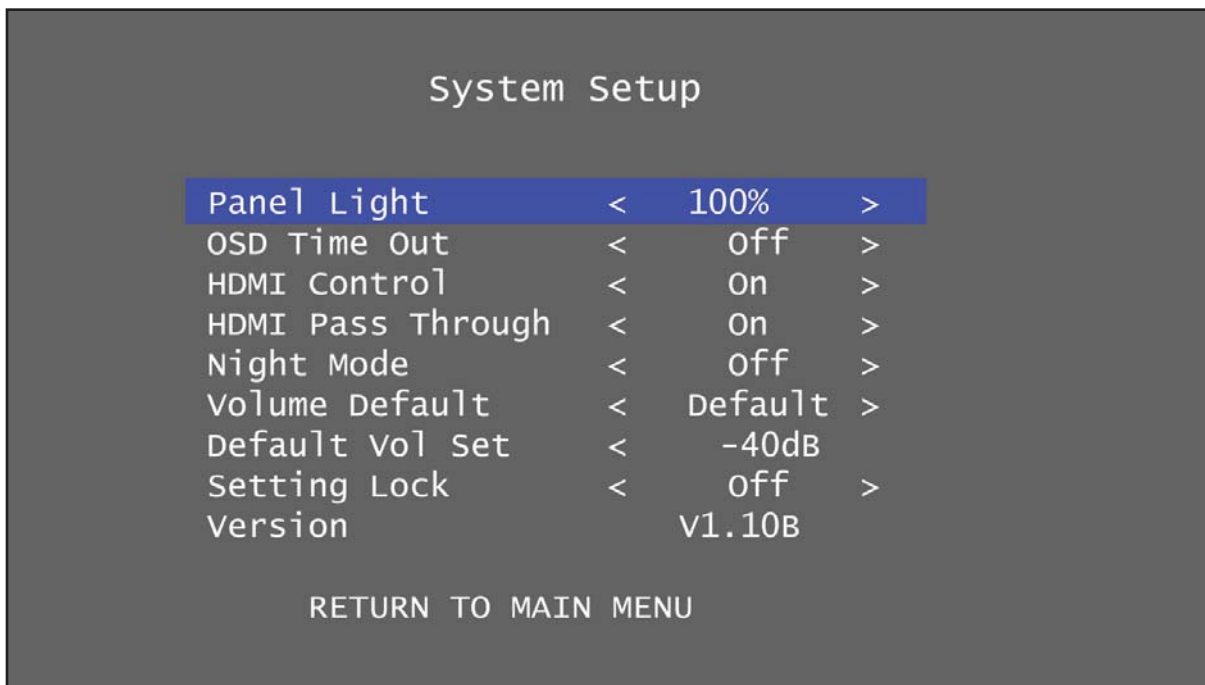

The System Setup menu contains menu options for general configuration of the Model 976.

Panel Light:

Set this value to control brightness of the front display panel. The default is 100% brightness. The available choices are:

OFF → 25% → 50% → 100%

OSD Time Out:

Use this control to define how long the on-screen menu is visible without user input. The default setting of "Off" will allow the menu to stay visible indefinitely. The available choices are:

30 seconds → 1 minute → 3 minutes → 5 minutes → Off

HDMI Control:

Set to "On" (default setting) to allow Consumer Electronics Control (CEC) of devices via HDMI connections. When enabled, commands such as power on/off, input selection, or volume control that are sent to one compatible device may be shared via HDMI connection to other devices. Set to "Off" to disable this control. The available choices are:

On → Off

Note: While CEC is an industry standard, some manufacturers use different brand names for the protocol. While many standard commands are available, each manufacturer may choose to implement them differently.

HDMI Pass Through:

Set to "On" (default setting) to allow video signal pass-through even when the Model 976 is in standby mode. In this case, the last HDMI input selected will continue to be passed to the HDMI output. Set to "Off" to only allow HDMI output from the Model 976 when the unit is on. The available choices are:

On → Off

Night Mode:

This mode affects soundtracks produced in Dolby Digital, Dolby Digital Plus, or Dolby TrueHD. It employs dynamic range compression (DRC), which quiets the loud peaks in a soundtrack while retaining the same volume level for dialogue. There are three modes. "Auto" activates DRC using instructions encoded in the soundtrack itself; you may have more or less DRC effect depending on how the engineers produced the soundtrack. "On" activates DRC for all Dolby soundtracks. "Off" deactivates DRC entirely. This setting can also be changed from the remote control using the "NIGHT" button. The available choices are:

On → Off → Auto

Volume Default:

Set to "Default" to automatically start the Model 976 at a specific volume setting or "Last" to start at the last volume selected when the Model 976 was placed in Standby.

Default → Last

Default Vol Set:

Select the start-up volume setting to be used with "Default" volume setting. This setting may be anywhere from -70dB to -40dB in 1dB increments.

Setting Lock:

Set to "On" to lock all menu settings or "Off" (default) to allow menu adjustments.

On → Off

Version:

Displays firmware version installed on your Model 976.

Return to Main Menu:

Select this menu option to return to the Main Menu.

Input Setup

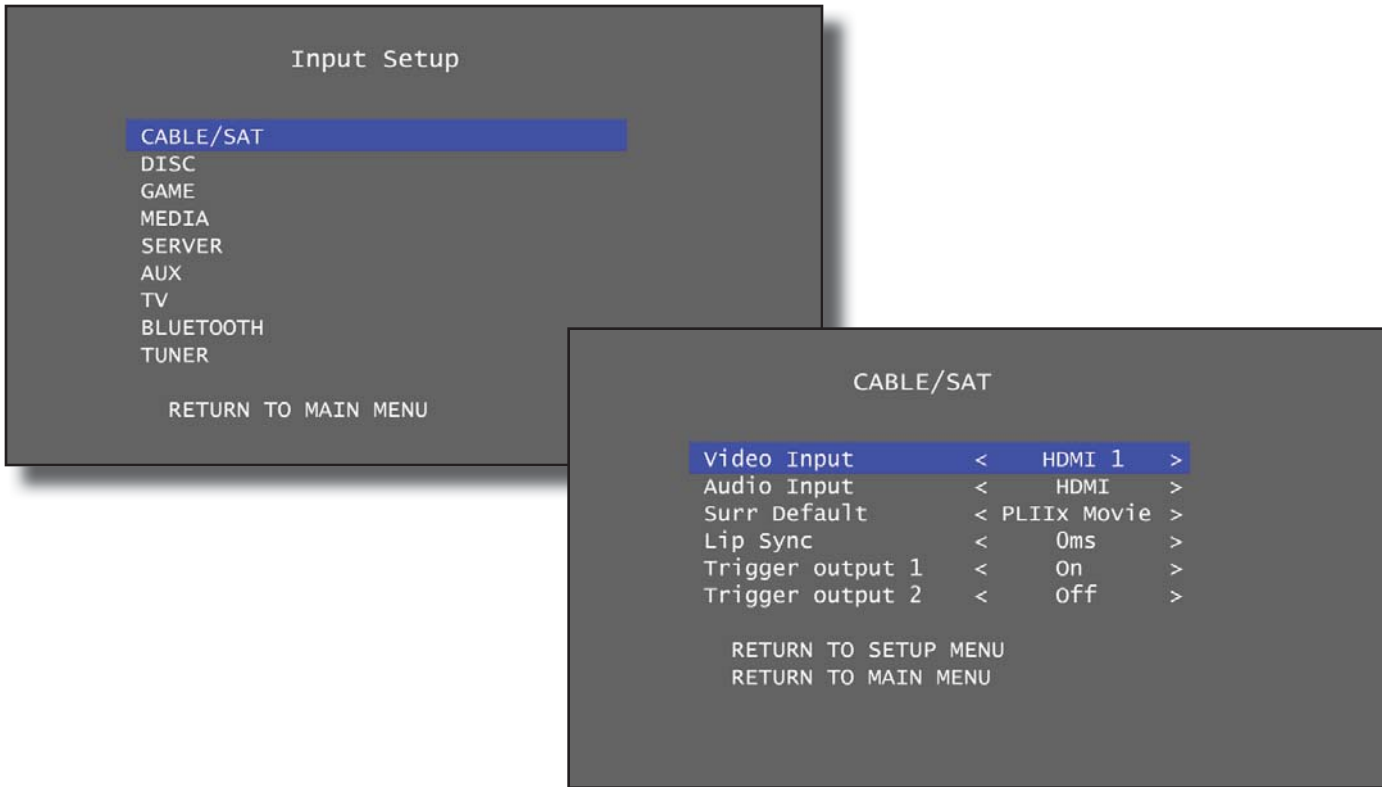

The Input Setup menu allows custom adjustments to each of the Model 976's inputs. Most of these inputs are "software" inputs that can be assigned to the various digital and analog rear panel connections used to connect sources to the Model 976 in the "Connecting Your Model 976" section. The inputs include Cable/Sat, Disc, Game, Media, Server, Aux, TV, Bluetooth, and Tuner. Refer to the Input Summary Sheet (page 46) for details on how each source is connected to your Model 976.

- All HDMI inputs can be assigned to the CBL/SAT, DISC, GAME, MEDIA, SERVER, and AUX inputs.
- The audio selections are fixed for the BLUETOOTH (BT) and TUNER (TNR) inputs to the bluetooth and tuner respectively. For video, you may select HDMI IN 1-6.
- The video selection for TV is fixed to NONE. For audio, you may select coax, optical, HDMI ARC, analog stereo, and 7.1 analog inputs.

Video Input:

Select from HDMI inputs HDMI1 through HDMI6.

Note: This option is disabled for the TV input. The default Video setting is also "NONE" for the Bluetooth and Tuner inputs.

Audio Input:

Select HDMI (default) to get audio from the assigned HDMI video input. Select "Coax1", "Coax2", "Opt1", or "Opt2" for a coaxial or optical digital audio input. Select "Analog1" through "Analog 4" for a stereo analog audio input. To use the Audio Return Channel with your TV, select "HDMI ARC" with the TV input. This will allow the TV input to use audio from the TV to the HDMI Out 1 output of the Model 976.

Note: This option is disabled for the Bluetooth and Tuner inputs.

Surr Default:

This determines which surround processing mode is used by default for the input. Options include Dolby Pro Logic II Movie ("PLII Movie"), Pro Logic II Music ("PLII Music"), Pro Logic II Game ("PLII Game"), DTS Neo:6 Cinema ("Neo6 Cinema"), DTS Neo:6 Music ("Neo6 Music"), All Channel Stereo ("ALL CH ST"), and Auto ("Auto"). See the "Listening Modes" section of the manual (page 14) for details on these processing modes.

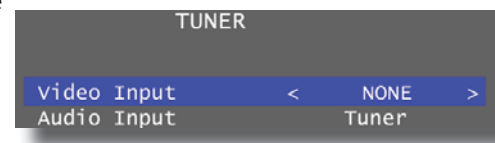
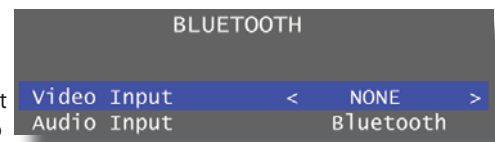
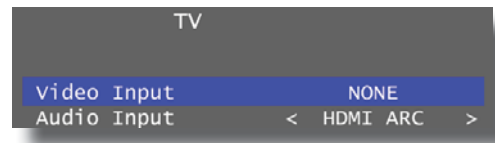

Speaker Setup

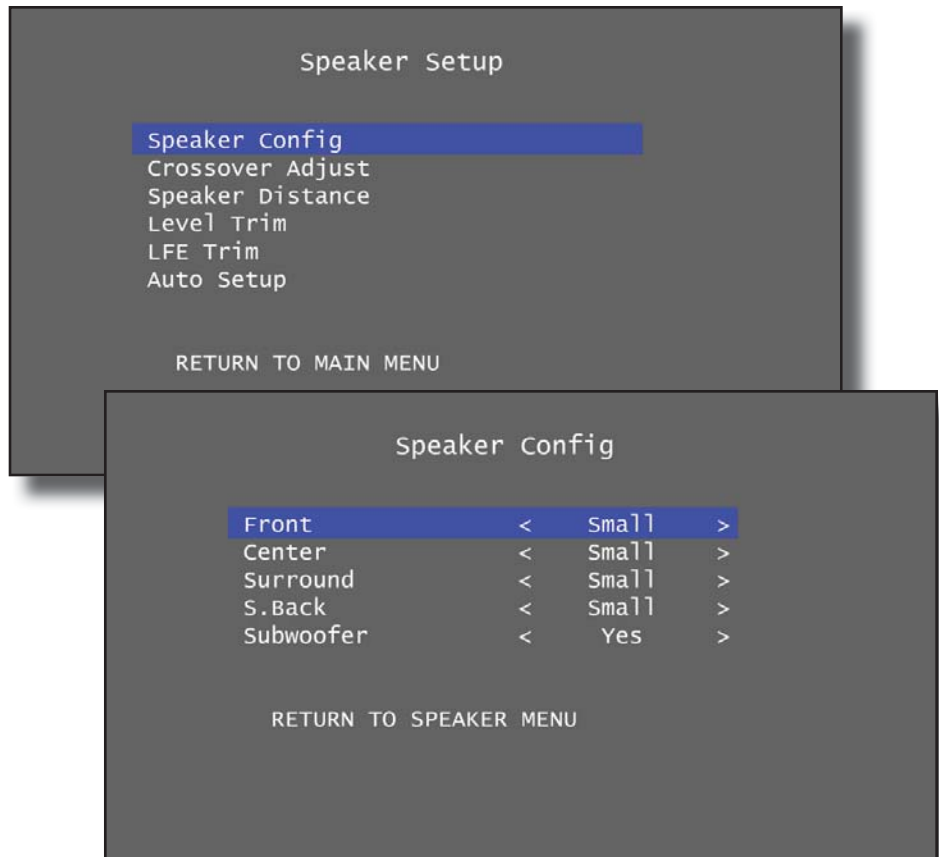

Lip Sync:

Adjust the amount of audio delay applied to the input to synchronize audio and video. This can be necessary with sources that employ significant video processing, resulting in the audio playing back before the video. Lip sync can be adjusted in 10ms increments from 0ms (default) to 500ms (half a second).

Trigger Output 1:

Select "On" (default) to energize Trigger Output 1 when the input is selected or "Off" to turn off Trigger Output 1 when the input is selected.

Trigger Output 2:

Select "On" to energize Trigger Output 2 when the input is selected or "Off" (default) to turn off Trigger Output 2 when input is selected.

Return to Setup Menu:

Select this menu option to return to the Input Setup menu and choose a different input to configure.

Return to Main Menu:

Select this menu option to return to the Main Menu.

The Speaker Setup menu allows you to specify what speakers are connected to the Model 976, set trim and distance values for each speaker, configure bass management settings, and run the Auto Setup routine.

Speaker Config Sub-Menu:

There are five speaker options in the Speaker Configuration menu: Front, Center, Surround, Surround Back (S.Back), and Subwoofer. The Front speakers can be set to Large or Small. The Center and Surround speakers can be set to Large, Small, or None. The Surround Back speakers can be set to Large, Small, or None, but can only be set to Large if the Surround speakers were also set to Large. Lastly, the Subwoofer can be set to Yes or None.

"Large" refers to a speaker that can accurately reproduce low frequency audio approaching 20Hz. "Small" refers to a speaker that is unable to reproduce audio at such low frequencies. We recommend you follow the speaker manufacturer's suggestions for the speaker size (Large or Small) and Speaker Crossover settings. However, we understand that manufacturers often fail to provide such recommendations.

In general, select Large only if your speakers are capable of handling deep bass down to at least 30 Hz (see the frequency response specifications for your speaker and look at the lower number in the response range) or if you are not using a subwoofer. Otherwise, select Small and set the Speaker Crossover frequency to suit the speaker.

Crossover Adjust

Front	<	80Hz	>
Center	<	80Hz	>
Surround	<	80Hz	>
Surround Back	<	80Hz	>

RETURN TO SPEAKER MENU

Speaker Distance

Units	<	Feet	>
Front Left	<	10.0 FT	>
Center	<	10.0 FT	>
Front Right	<	10.0 FT	>
Surround Right	<	10.0 FT	>
Surround Back R	<	10.0 FT	>
Surround Back L	<	10.0 FT	>
Surround Left	<	10.0 FT	>
Subwoofer	<	10.0 FT	>

RETURN TO SPEAKER MENU

Crossover Adjust Sub-Menu:

Each of the first four speaker options from the Speaker Configuration menu has a separate crossover setting that can be adjusted in this menu. Crossovers may be set from 40Hz to 200Hz in 10Hz increments, with the default crossover setting being 80Hz for each speaker. This crossover will only be applied if speakers are set to "Small" in the Speaker Configuration menu. To adjust the crossover settings, highlight a speaker set with the up and down navigation buttons and use the left and right navigation buttons to select the desired crossover setting for each.

Deciding what crossover setting to use can be difficult. For smaller tower speakers, a crossover point of 40 or 50 Hz is usually about right. For bookshelf speakers, center speakers and surround speakers, 80 Hz usually works. For satellite, center and surround speakers with woofers smaller than 5 inches in diameter, 120 or 150 Hz will probably work best. The maximum crossover frequency of 200 Hz should be used only with very small, "cube"-type satellite speakers.

Speaker Distance Sub-Menu

You may choose to skip this step if you plan to use the auto setup feature, as the Model 976 will set the speaker distances. Some users may prefer to double-check the measurements, however.

Grab a tape measure and measure the distances from each speaker (and the subwoofer) to where your head would be positioned when you're in your favorite listening seat. Measure to the nearest 6 inches if you're using English measurements, or to the nearest 1/10th of a meter if you're using metric. Write these numbers down.

If you're still in the Speaker Configuration submenu, hit the MENU button to back out of it. If you're starting from scratch, hit MENU then hit ENTER to select the Speaker Setup submenu.

Press the down arrow (▼) key to select the Speaker Distance submenu, then hit ENTER.

Use the left and right arrow keys (◀▶) to select entry in feet or meters.

Press the down arrow key to move to Front Left. Now use the left and right arrow keys to set the distance for the front left speaker.

Repeat the process for all speakers in the system. Note that any speakers set to "None" in the Speaker Config menu will be disabled here.

Level Trim Sub-Menu

The Model 976 includes an automatic speaker setup tool that adjusts channel levels, but we also offer the ability to manually adjust levels. If you plan to use the automatic setup tool, you may choose to skip this menu. If you want to make your own adjustments manually, this is the place to do it.

While it's possible to "rough in" the channel levels by ear, you'll get much better results by using a sound pressure level (SPL) meter. You can use either a dedicated meter like those sold under the RadioShack and Galaxy brands, or if you have a smartphone, use an SPL meter app. Search your iPhone's App Store or your Android's Play Store for "SPL meter." Most are available for free or at low cost.

Level Trim

Test Tone	<	Off	>
Front Left	<	0dB	>
Center	<	0dB	>
Front Right	<	0dB	>
Surround Right	<	0dB	>
Surround Back R	<	0dB	>
Surround Back L	<	0dB	>
Surround Left	<	0dB	>
Subwoofer	<	0dB	>

RETURN TO SPEAKER MENU

LFE Trim

Sub Trim	<	0dB	>
DD/DTS Trim	<	0dB	>
DD/DTS Bass Aug	<	Off	>
DPLII/DTS Neo Trim	<	0dB	>
DPLII/DTS Neo Bass Aug	<	Off	>
Stereo+Sub Trim	<	0dB	>

RETURN TO SPEAKER MENU

This process can be quite loud, so be prepared to adjust levels quickly. The master volume control cannot be adjusted once you are in the OSD. To adjust the master volume, you would need to back out of the OSD.

Set your Model 976's volume control to -20dB on the front panel display. Hit MENU, hit the down arrow (▼) key then hit ENTER to select the Speaker Setup submenu.

Press the down arrow (▼) key to select the Level Trim submenu, then hit ENTER.

Sit down in your favorite listening seat. Turn on the SPL meter (or activate the SPL meter app on your phone). Set the range (if necessary) to 70 dB. Set the weighting to C-Weighted Slow.

Use the right arrow key (▶) to activate the test tone. While you can make adjustments without activating the test signal, in almost all cases you'll get best results by using the test signal. When you activate the test signal, the highlighted box will move down to Front Left, and you should hear the test noise coming from the front left speaker.

Use the left and right arrow keys (◀▶) to set the level so that the SPL meter reads 75 dB. (You can use 85 dB if it's convenient—but 75 dB is the standard in home theater calibration.)

Use the down arrow key to move the test noise to Center, and use the left and right arrow keys to set the level so it matches the level of the front left speaker.

Repeat the process for all other speakers in the system. For any speakers that were set to "None" in the Speaker Config menu, adjustment of level trim will be disabled on this screen.

If you are using a subwoofer, you may find that its level control needs to be adjusted in order to achieve a balance with the other speakers. Re-adjust the subwoofer level control if necessary to the approximate level you need, then use the Model 976's Subwoofer setting in the Level Calibration submenu to fine-tune it.

LFE Trim Sub-Menu

This control reduces the level of the LFE (or ".1") component of a 5.1 or 7.1 soundtrack. It does not affect signals from other channels. Use if you find the bass in movie soundtracks to be too loud. Separate adjustments are available for different audio formats and processing modes. There's no "proper" setting, so whatever sounds good to you is correct. The default is 0dB.

Sub Trim: Set from -10dB to 0dB (default) to reduce subwoofer output if the low frequency is overwhelming the other speakers' output. The available choices are:

-10dB → -9dB → -0dB → -7dB → -6dB → -5dB → -4dB → -3dB → -2dB → -1dB → 0dB

DD/DTS Trim: This adjustment lets you alter the level of the subwoofer output when Dolby Digital and DTS soundtracks are playing. This does not affect the subwoofer level with non Dolby Digital/DTS material. Use if you want a little more or a little less bass when this material is playing. Default value is 0dB. The available choices are:

-5dB → -4dB → -3dB → -2dB → -1dB → 0dB → +1dB → +2dB → +3dB → +4dB → +5dB

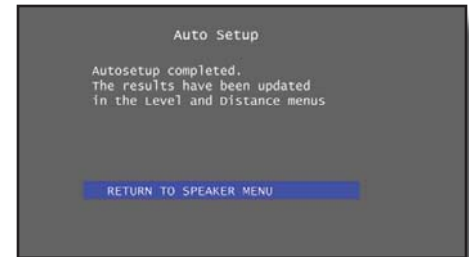
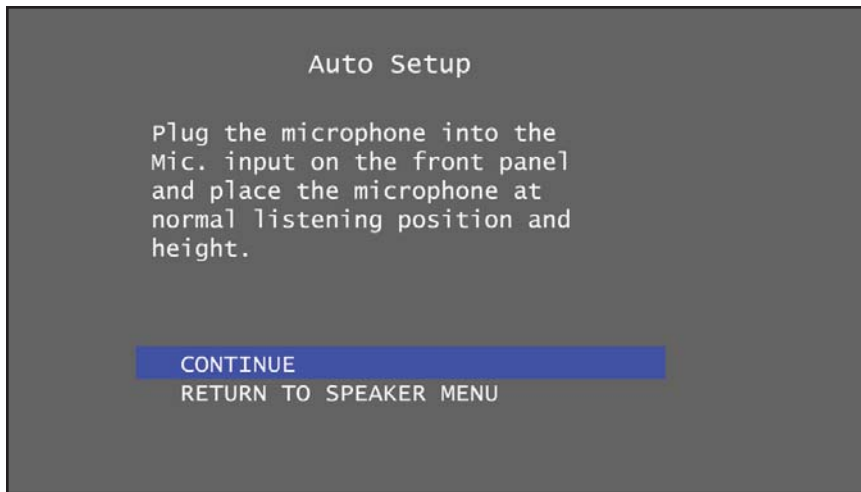
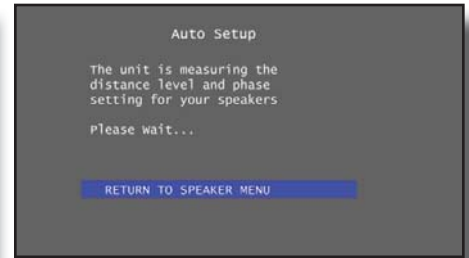
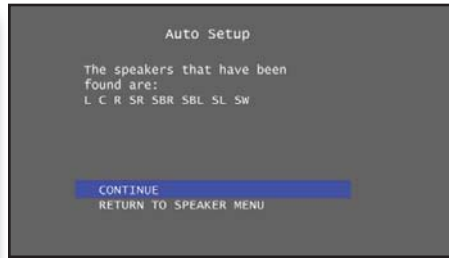

DD/DTS Bass Augmentation: This mode can enhance bass performance during Dolby Digital and DTS soundtrack playback. It works only if the front speakers are set to Large. In this mode, the signal to the front left and right speakers is unaltered, but the bass component of that signal is also sent to the subwoofer, so you can get enhanced bass output. The available choices are:

On → Off

DPLII/DTS Neo Trim: Set from -5dB to +5dB to apply an increase or decrease in subwoofer output with Dolby Pro Logic II and DTS Neo:6 surround processing modes. Default value is 0dB. The available choices are:

-5dB → -4dB → -3dB → -2dB → -1dB → 0dB → +1dB → +2dB → +3dB → +4dB → +5dB

DPLII/DTS Neo Bass Augmentation: This mode can enhance bass performance when a Dolby Pro Logic II or DTS NEO:6 mode is engaged. It only works if the front speakers are set to Large. In this mode, the signal to the front left and right speakers is unaltered, but the bass component of that signal is also sent to the subwoofer. The available choices are:

On → Off

Stereo+Sub Trim: Set from -5dB to +5dB to apply an increase or decrease in subwoofer output when playing a stereo audio source with small front speakers. Default value is 0dB. The available choices are:

-5dB → -4dB → -3dB → -2dB → -1dB → 0dB → +1dB → +2dB → +3dB → +4dB → +5dB

Auto Setup Sub-Menu

A special set-up microphone was provided with your Model 976. To use the Automatic Setup routine, plug this microphone into the front panel Set-Up Mic jack and place the microphone in the preferred listening position at approximately ear-level.

The Model 976 will prompt you to verify that the setup microphone is plugged in and placed in the normal listening position. Press "Continue" to start auto setup.

The first step of auto setup is verification of connected speakers. The Model 976 will use a test signal to confirm that all speakers set to either large or small in the Speaker Config menu. When that is complete, it will list each detected speaker and prompt you to continue. Press "Continue" to move to the next step.

The second step of auto setup is measuring speaker distances and phase settings. The Model 976 will use another set of test signals to verify phase and set speaker distances. When complete, it will revise any speaker distance settings you made in the Speaker Distance menu. After this step, the Model 976 will report that the auto setup process is complete and allow you to return to the Speaker Setup Menu.

EQ Adjust

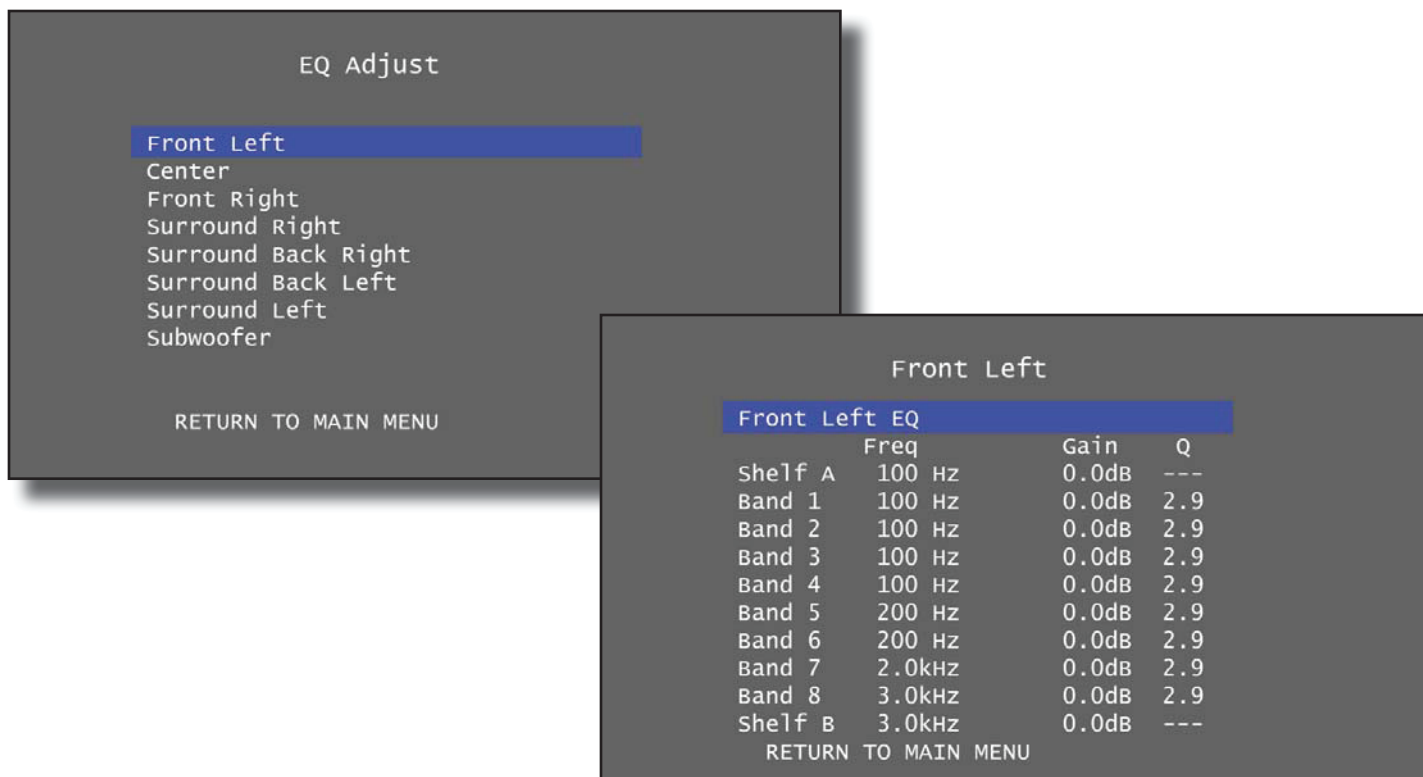

The Model 976 offers an adjustable equalizer for each speaker. Users may choose to manually adjust the equalizer channels for each speaker, or they may utilize an external program such as Room EQ Wizard (REW) to analyze their room and make adjustments to remove artifacts created by room acoustics.

Note: Because the Model 976's 7.1 ch input stays analog through and through, the EQ does not affect it. This also means you will want to use an HDMI output from your computer to an HDMI input on the Model 976 should you chose to utilize REW.

Each speaker has two shelves and eight bands. Shelves are applied to frequencies below or above the specified frequency. Shelf A is applied to the specified frequency and everything below that frequency. Shelf B is applied to the specified frequency and everything above that frequency. Bands are applied to the specified frequency. For each shelf, the frequency and gain can be adjusted. For each band, the frequency, gain, and Q can be adjusted. To adjust the settings, highlight a shelf or band with the up and down navigation buttons, select it with the Enter button, and use the left and right navigation buttons to place a cursor behind the "Freq", "Gain", or "Q" setting. Once a setting is selected, use the up and down navigation buttons to adjust the setting's value. When finished, press

Enter again and use the up and down navigation buttons to highlight additional shelves or bands.

Frequency: The frequency associated with the equalizer band or shelf, either the center frequency for a band or the boundary frequency for a shelf.

Each shelf and band frequency may be set between 10Hz and 200Hz in 1Hz increments, from 210Hz to 2kHz in 10Hz increments, and from 2.1kHz to 20.0kHz in 0.1kHz increments.

Gain: The amount of increase or decrease in signal applied at the frequency.

Each shelf and band gain may be set between -20.0dB and +3.0dB in 0.5dB increments.

Q: The ratio of frequency to bandwidth. This controls how wide or narrow a range of frequencies are affected by the equalizer band. A higher Q value affects a narrow range of frequencies, which can allow for boosting or reducing a specific frequency. A lower Q value affects a wider range of frequencies. This setting does not apply to shelves.

Each band Q may be set to 0.5, 1.0, 1.4, 2.0, 2.4, 2.9, 3.6, 4.8, 7.2, or 14. The default Q is 2.9.

Audio Setup

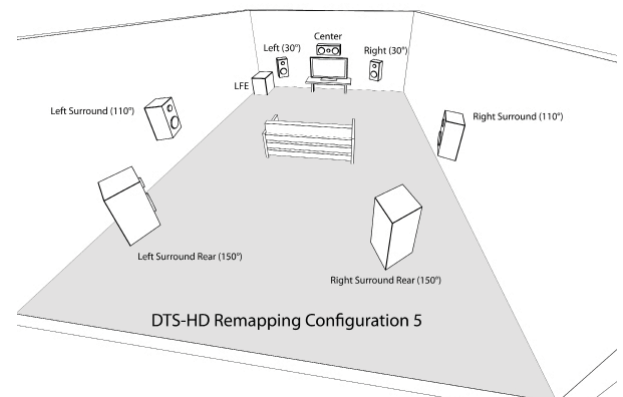
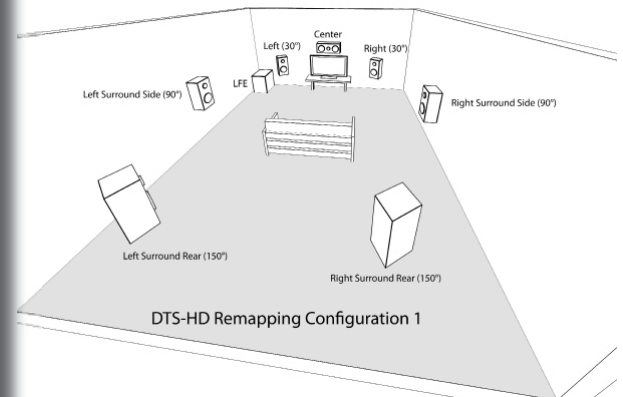

Options for Audio Setup include treble, bass, Dolby Pro Logic II, DTS, and DSP bypass.

Treble / Bass: Adjust the treble and bass settings from -10dB to +10dB. The default for each is 0dB. These settings may also be adjusted directly from the remote using the Tone button. The available choices are:

-10dB → -8dB → -6dB → -4dB → -2dB → 0dB → +2dB → +4dB → +6dB → +8dB → +10dB

Dolby Pro Logic II offers three settings that can be adjusted in this menu to control how the Pro Logic II Music mode behaves. Note that these settings do not apply to Pro Logic II Movie or Game.

Panorama: When set to "On", Pro Logic II Music will extend the front soundstage into the surrounds. This may also be set to "Off" (default) to focus the audio in the front soundstage.

Center Width: Set from 0 to 7 (default of 3) to control how much the center channel data is spread across the left and right channels. A center width of 7 will redirect all center channel data to the left and right channels. The available choices are:

0 → 1 → 2 → 3 → 4 → 5 → 6 → 7

Dimension: Set from 0 to 7 (default of 7) to control how much the soundstage is shifted into the surrounds when Panorama is on. A setting of zero will cause Pro Logic II to steer more information in the surrounds. A setting of more than zero will pull the soundstage toward the fronts, reducing surround activity. The available choices are:

0 → 1 → 2 → 3 → 4 → 5 → 6 → 7

DTS-HD Speaker Remap: This is a setting developed by DTS to address the lack of a single standard speaker layout for channel mapping when surround sound is mastered. DTS defined seven possible speaker configurations that may be used in the mixing stage. By specifying the configuration that most closely matches your speaker layout, DTS will attempt to re-map audio channels that are flagged as belonging in one of the other layouts. The DTS standard includes seven speaker configurations that are available for surround sound mastering. Of these, two configurations are supported by the Model 976's 7.1 channel output. (Other mapping plans include such speaker arrangements as height speakers, ceiling center height, and mono rear surround speakers.) The default setting is configuration 1, but configuration 5 is also available. Both possible configurations are pictured above.

We recommend configuration 5 if your surround speakers are located behind the primary listening position rather than directly to the sides. The available choices are:

1 → 5

DTS NEO:6 Center Gain: This setting is similar to Pro Logic II's Center Width setting, but is applied before the center channel signal is derived from the stereo source. When Center Gain is set to 0 (the minimum setting), both left and right channels are attenuated by half in order to create the center channel signal. A Center Width setting of 5 applies no attenuation to the left and right channels, preserving the original stereo signal. The default is 2. The available choices are:

0 → 1 → 2 → 3 → 4 → 5

DSP Bypass: This is set to "Off" by default and allows the Model 976 to apply surround processing, but can be turned "On" to defeat any surround processing modes. The available choices are:

On → Off

Operation

Now that your Model 976 is properly connected and configured, you're ready to enjoy it! We designed the Model 976 to be simple and intuitive, so for most of its operations you probably don't need to read the manual. However, it's worth browsing through the operation instructions so that you don't miss out on any of the Model 976's useful features.

Although you've already used the menus and on-screen display to set up the Model 976, many of its settings can be changed "on the fly," directly from the remote, without going through the menus.

Turn the Model 976 on

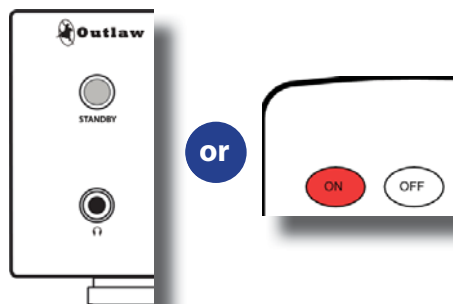

Turn the Model 976 off

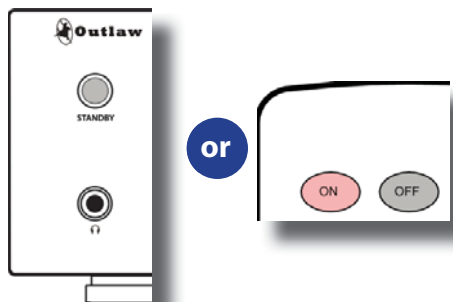

Selecting an input

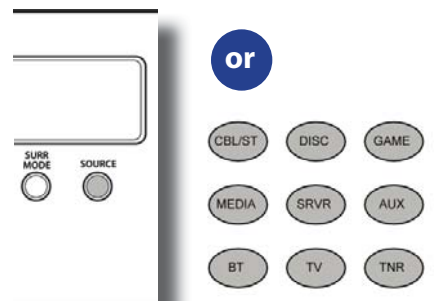

Front Panel Display



Chapter 4 Contents

- 33 Power
- 33 Selecting a Source
- 34 Volume Control
- 34 Muting
- 34 Changing the Surround Mode
- 35 Switching to Stereo
- 36 Adjusting Tone Controls
- 36 Adjusting Lip Sync Delay
- 36 Activating Night Mode (DRC)
- 37 Adjusting Channel Levels
- 38 Engaging EQ
- 38 Listening With Headphones
- 38 Setting Sleep Timer

To turn the Model 976 on and off:

1. To turn the unit on, press the STANDBY button on the front panel or the POWER ON button on the remote. The front panel display will illuminate and the ring around the STANDBY button will glow brighter.
2. To turn the unit off, press the STANDBY button on the front panel again or press the OFF button on the remote control. The front panel display will go out and the ring around the STANDBY button will dim.

The Model 976 lets you select from as many as nine sources, which are labeled Cable/Sat, Disc, Game, Media, Server, Aux, TV, Bluetooth, and Tuner. The first seven of these can be configured to carry signals from any audio or audio/video source device you wish. To find out how to configure those inputs, see page 26.

To select a source:

Press one of the dedicated source buttons (Cbl/St, Disc, Game, Media, Srvr, Aux, BT, TV, or Tnr) on the remote control, or press the INPUT button on the front panel to cycle through the input sources. The front panel display will show the source you have selected, as seen above.

Volume Control

Increasing or decreasing the volume level

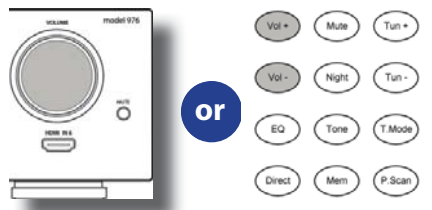

Front Panel Display



Muting

Turning Mute on and off

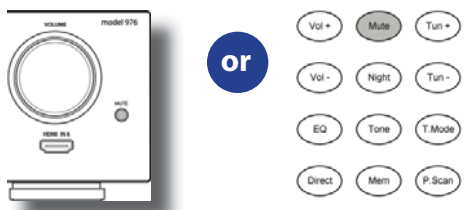

Front Panel Display



Changing the Surround Mode

To activate available surround modes

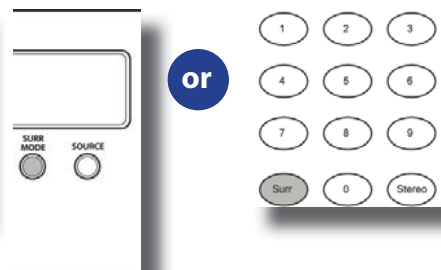

Use this control to adjust the volume level of all currently connected speakers.

To adjust the volume level:

Press the VOL + or – button on the remote, or turn the VOLUME knob on the front panel. The volume level in decibels (dB) will be shown on the front panel display as seen below.

Minimum volume setting is -90 dB. The maximum volume setting may vary depending on how you have set the levels of the individual channels. Setting trims to higher than 0 dB may reduce the maximum volume setting.

Use this control to turn the sound off momentarily.

1. **Press the MUTE button on the remote control or the front panel.**
The sound will be muted and the front panel display will read MUTE ON, as seen below:
2. **Press either MUTE button again to restore the volume to its previous level.**

The SURR MODE control activates the Model 976's matrix surround sound modes, and changes the surround mode from the one currently selected. The modes available will depend on whether the incoming signal is stereo or 5.1/6.1/7.1, and what speaker configuration you are using. If you are unsure about which mode you want to use, refer to the Audio Formats and Listening Modes section of this manual (pages 13 and 15).

If the Model 976 is receiving a stereo (2-channel) signal and you are using a 5.1 or 7.1 speaker setup, you will be able to choose among these modes:

Dolby Pro Logic II Movie → Dolby Pro Logic II Music → Dolby Pro Logic II Game → DTS NEO:6 Cinema → DTS NEO:6 Music → All Channel Stereo.

If you are using a 7.1 speaker setup, Pro Logic IIx will be employed instead of Pro Logic II.

Switching to Stereo

Matrix surround modes with stereo (2-channel) source

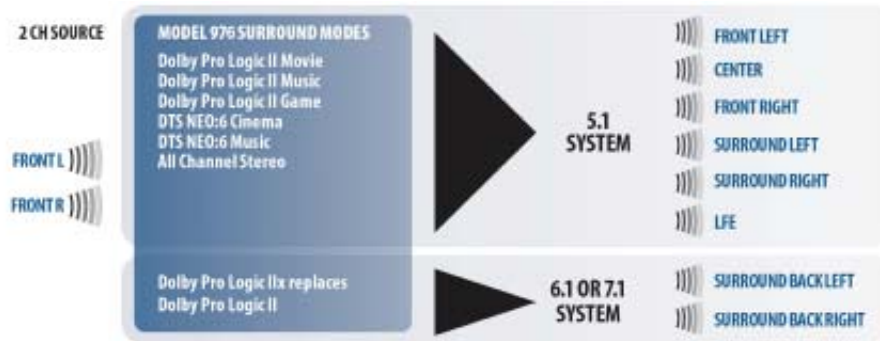

To deactivate surround mode and switch to stereo

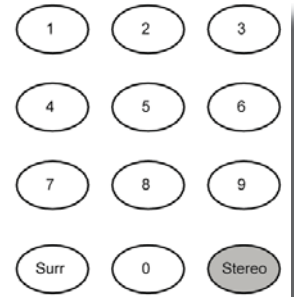

Matrix surround modes with 5.1 source

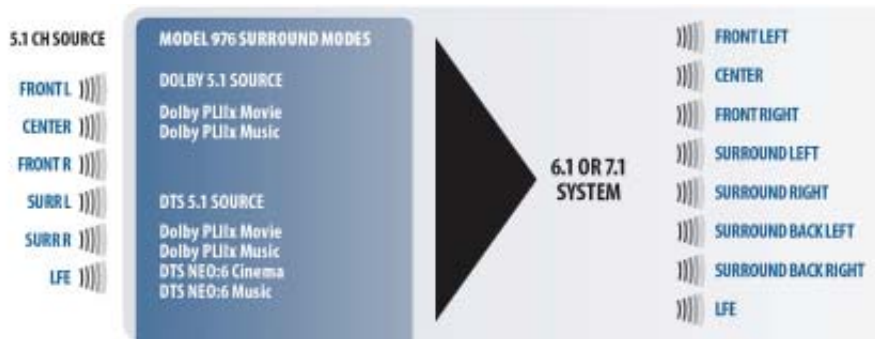

If the Model 976 is receiving a 5.1 signal and you have a speaker system using back surround speakers (7.1), pressing the SURR MODE button when 5.1 material is playing will let you expand the two surround channels into four surround channels. With Dolby 5.1 material, you can access three surround modes:

Dolby PLIIx Movie → Dolby PLIIx Music → Dolby PLIIx Game

When DTS 5.1 or multichannel PCM material is playing, you can access these surround modes:

Dolby PLIIx Movie → Dolby PLIIx Music → Dolby PLIIx Game → DTS NEO:6 Cinema → DTS NEO:6 Music

If the Model 976 is receiving a 6.1 or 7.1 signal and you have a speaker system using back surround speakers (7.1), there will be no available surround sound modes.

To activate one of the Model 976's surround modes:

- 1. Press the SURR MODE button on the remote or the front panel.**
The front panel display will read out the currently selected surround mode or, if no surround mode has been selected, the format of the incoming signal. If a digital 5.1 or 7.1 soundtrack is playing, you will see a readout of the format of that material and its channel content, such as DOLBY DIGITAL [3/2].1. The first number in the parentheses is the number of front channels, while the second number is the number of surround channels. The ".1" after the parentheses indicates the presence of a low-frequency effects (LFE) channel.
- 2. Press the SURR MODE button again to change the surround mode.**
The front panel display will show which mode is selected.
- 3. Press the SURR MODE button repeatedly until the mode you want is selected.**

The Model 976 lets you deactivate surround sound and switch to stereo at the push of a button. If you have a subwoofer in your system, the subwoofer can function in stereo mode.

To switch the Model 976 to stereo mode:

- 1. Press the STEREO button on the remote control.**
Any surround sound mode currently in use will be deactivated, and the front panel display will read either STEREO or STEREO+SW (stereo plus subwoofer), depending on your speaker configuration settings.
- 2. To go back into surround sound, press the SURR MODE on the remote or the front panel.**

Adjusting Tone Controls

Accessing the tone controls

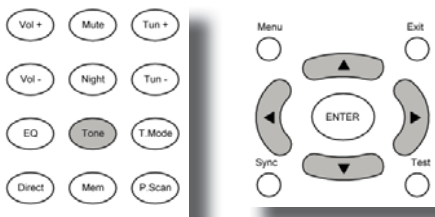

Front Panel Display



The Model 976 has bass and treble controls that can boost or cut in 2dB steps, to a maximum ± 10 dB. These controls can be used to fine-tune the sound of your system for all material, or just for certain movies or music that need a bit of tweaking.

The bass and treble settings can be adjusted using the remote control and the front panel display, or through the menu. To adjust these controls through the menu/OSD, see page 32.

To adjust the bass and treble:

1. Press the **TONE** button on the remote. The front panel display will show the setting of the bass control, as seen above
2. Press the up or down buttons (**▲** or **▼**) on the remote to set the level of bass boost or cut in dB.
3. Press the **TONE** button again to set the treble. The front panel display will show the setting of the treble control, such as TRB -2 dB.
4. Press the up or down buttons (**▲** or **▼**) on the remote to set the level of treble boost or cut in dB.

Adjusting Lip Sync Delay

Setting lip sync delay

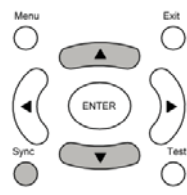

Front Panel Display



If you notice a lip sync problem with a movie or TV show you're watching, it's because the audio is taking less time to process than the video. (This problem appears to be most common when you're watching broadcast TV.) The Model 976 lets you delay the audio slightly to get the audio and video back in sync.

If you find that a particular source, such as a digital TV tuner, has a consistent lip sync problem, you can preset the lip sync for that source only through the Input Setup submenu (see page 27).

Use this control to adjust lip sync.

1. **Play the material (movie or TV show) in which you noticed the lip sync problem.**
2. **Press the SYNC button on the remote.** The front panel display will show the current audio delay setting, as seen above.
3. **Press the up or down buttons (▲ or ▼) on the remote to increase or decrease the lip sync delay in increments of 10 milliseconds (10 mS) up to 500 mS.** Experiment until you get the actors' lips in sync with the dialogue.

Activating Night Mode

Activating Night Mode (DRC)

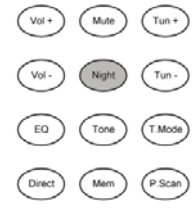

Front Panel Display



Night mode affects soundtracks produced in Dolby Digital, Dolby Digital Plus or Dolby TrueHD. It employs Dynamic Range Compression (DRC), which quiets the loud peaks in a soundtrack while retaining the same volume level for dialogue. There are three modes:

Auto activates DRC using instructions encoded in the soundtrack itself; you may have more or less DRC effect depending on how the engineers produced the soundtrack.
On activates DRC for all Dolby soundtracks.
Off deactivates DRC entirely.

Use this control to adjust night mode.

1. **Press the NIGHT button on the remote control.** The front panel display will show the currently selected DRC mode, as seen above.
2. **Press the NIGHT button repeatedly to change the mode to DRC on, DRC off or DRC Auto.**

Adjusting Channel Levels

Measuring Sound Pressure Levels

Sound Pressure Level (SPL) Meter

Use an SPL meter to accurately measure the difference in sound levels from each speaker in your system.

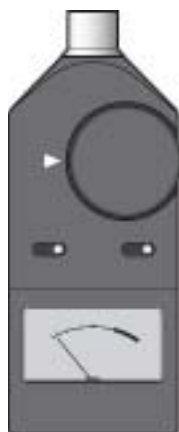

Smartphone SPL Meter App

If you have a smartphone, you can download an SPL meter app.



Adjusting channel levels of the Model 976

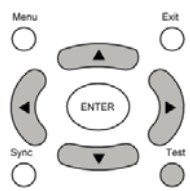

Front Panel Display

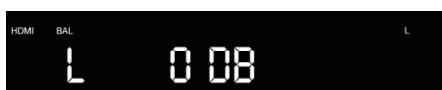

The Model 976 allows you to easily adjust channel levels two ways: while listening to source material during playback, or by using the internal test tones.

Adjusting the channel levels with the internal test tone can be accomplished by using either the remote control and front panel display or through the Model 976 setup menu and on-screen display. To set levels with the test tone using the on-screen display, see pages 28-29.

Adjusting the levels using source material is only possible using the remote control and front panel display because both audio and video inputs are interrupted when the on-screen display is in use.

As noted on page 28, it's possible to "rough in" the channel levels by ear, but better results are possible by using a sound pressure level (SPL) meter. You can use either a dedicated meter like those sold under the RadioShack and Galaxy brands, or if you have a smartphone, use an SPL meter app. Search your iPhone's App Store or your Android's Play Store for "SPL meter." Most are available for free or at low cost. Set the meter to C-Weighting Slow.

To adjust channel levels using the internal test tone generator:

1. **Sit down in the chair you want the sound optimized for, and turn on the SPL meter.**
Note: The master volume control cannot be used while adjusting channel levels. Set the volume to -20dB before going into the OSD.

2. **Press the "Test" button on the remote control. The front panel display will show TEST OFF. To enable the internal test tones, press up or down buttons (▲ or ▼) until you see TEST ON and then press ENTER on the remote.**

The front panel display will show the first channel to be adjusted along with the current level, as seen above, and the test tone will start.

3. **Press the up or down buttons (▲ or ▼) on the remote to increase or decrease the trim for the left channel.**

Adjust until you see 75dB on the meter. For RadioShack or Galaxy meters, make sure the meter is set to the 70dB range.

4. **Press the left or right buttons (◀ or ▶) on the remote to accept the channel level and change to the next channel.**

5. **Repeat the process for the remaining channels.**
The test tone will stop when you cycle through all of the channels or you press the TEST button again.

To adjust channel levels during playback:

1. **Start playing your source material.**
Note: The master volume control cannot be used while adjusting channel levels.
2. **Press the "Test" button on the remote control. The front panel display will show TEST OFF. Press ENTER on the remote.**
The front panel display will show the first channel to be adjusted along with the current level.
3. **Press the up or down buttons (▲ or ▼) on the remote to increase or decrease the trim for the left channel.**
4. **Press the left or right buttons (◀ or ▶) on the remote to accept the channel level and change to the next channel.**
5. **Repeat the process for the remaining channels.**
Normal mode will resume when you cycle through all of the channels or you press the TEST button again.

Engaging EQ

Turn EQ on or off

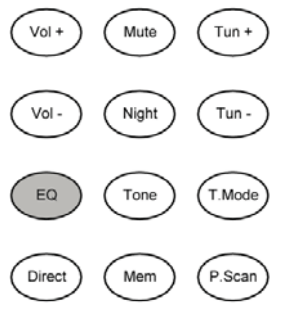

The Model 976 offers a ten-band equalizer with separate adjustments for each channel. Once configured, this EQ can be engaged or disengaged during playback.

To engage EQ during playback:

Press the EQ button on the remote.

The front panel will show "EQ ON" for several seconds. A momentary mute is normal.

Note: Adjusting the EQ cannot be done during playback. To adjust the EQ, you must use the on-screen display as described on page 31.

To disengage EQ during playback:

Press the EQ button on the remote.

The front panel will show "EQ OFF" for several seconds. A momentary mute is normal.

Listening with Headphones

Listening with headphones

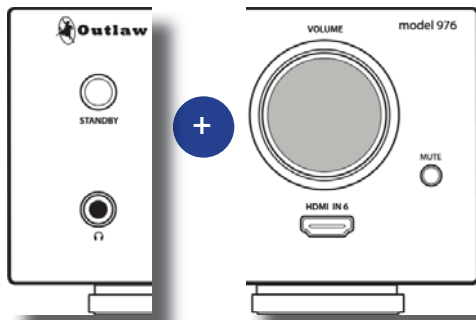

The Model 976's front headphone jack works with any standard headphones equipped with a 1/4-inch plug, or headphones equipped with a 1/8-inch plug and used with a 1/4- to 1/8-inch adapter.

IMPORTANT NOTE: We strongly recommend you reduce the Model 976's volume to a low setting of -30 to -40 dB before you play any material through your headphones, then bring the volume up to a comfortable listening level. Starting an audio source with the headphone level turned up high can result in hearing damage.

To use headphones with the Model 976:

1. **Select the source you want to listen to on the Model 976, and turn the volume down low, to -30 or -40 dB.**
2. **Plug in your headphones and put them on.** The main system sound will mute and you should hear your selected audio source.
3. **Turn the volume up slowly to a comfortable listening level.**
4. **Before changing sources, turn the Model 976's volume down, then raise it again to a comfortable level after the audio is playing.**

Setting Sleep Timer

Enabling sleep timer



The Model 976's sleep timer automatically shuts the unit off after a predetermined amount of time.

To activate the sleep timer:

1. **Press the the remote control's "Sleep" button.** The front panel display will show "Sleep" and the number of minutes until the unit shuts off immediately after the word "Sleep."
2. **Press the Sleep button repeatedly until you've chosen the amount of "sleep time" you want.** The available choices are:
0.5HR→1.0HR→1.5HR→2.0HR→2.5HR→3.0HR→3.5HR→4.0HR→OFF

Tuner Operation

The AM/FM tuner built into the Model 976 can be tuned to any of 20 AM and FM stations that you set into memory. It can also be tuned manually. Radio reception requires that appropriate AM and FM antennas be connected to the Model 976's rear panel (see page 9).

Activating the Tuner and selecting a band

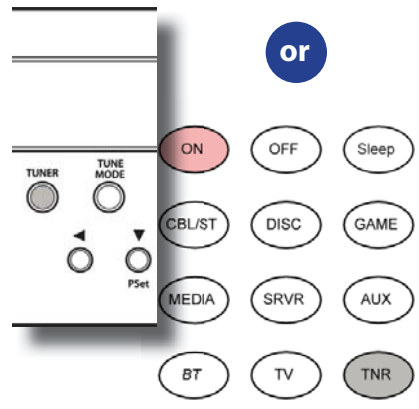

Tuning to a radio station

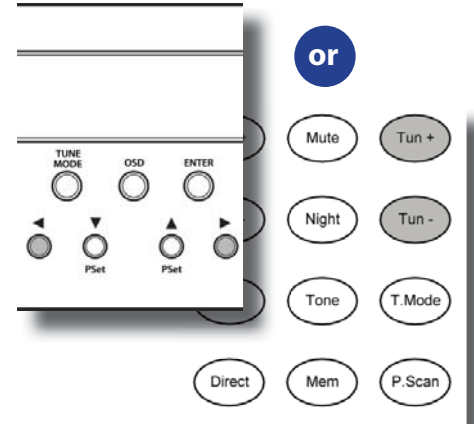

Chapter 5 Contents

- 39 Select Tuner and Band
- 39 Tune a Station Manually
- 40 Create Memory Presets
- 40 Select a Preset Station
- 40 Tune Stations Directly
- 41 Select FM Mono

To select tuner and band from the remote control:

1. **Press the TNR button on the remote control.**
You will hear the radio station and band that were last playing, and the front panel display will show you the band and frequency as shown above.
2. **Press the TNR button on the remote control again to switch to the other band.**

To select tuner and band from the front panel of the Model 976:

1. **Press the SOURCE button on the front panel until the display shows TUNER.**
Alternatively, you can press TUNER on the front panel to jump directly to the tuner input.
2. **Press the TUNER button on the front panel to switch to the other band.**

To tune a radio station manually using the remote control:

1. **Press the "tune +" button to go to a higher frequency or the "tune -" button to go to a lower frequency.**
Each push will change the frequency by 0.1 MHz in FM or 10 KHz in AM.
2. **To automatically scan to the next station, hold either the "Tune +" or "Tune -" button down for about 1 second and release it.**
The scan will stop when the Model 976's tuner finds the next active frequency. Pressing the Tune +/Tune - buttons again will also stop the scan.

To tune a radio station manually using the front panel:

1. **Press the left or right buttons (◀ or ▶) to tune to a lower or higher frequency.**
Each push will change the frequency by 0.1 MHz in FM or 10 KHz in AM.
2. **To automatically scan to the next station, hold the left or right buttons (◀ or ▶) for about 1 second and release it.**
The scan will stop when the Model 976's tuner finds the next active frequency.

Create Memory Presets

Creating a memory preset

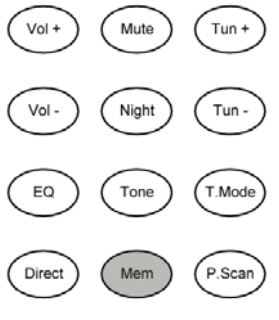

Select a Preset Station

Selecting a memory preset

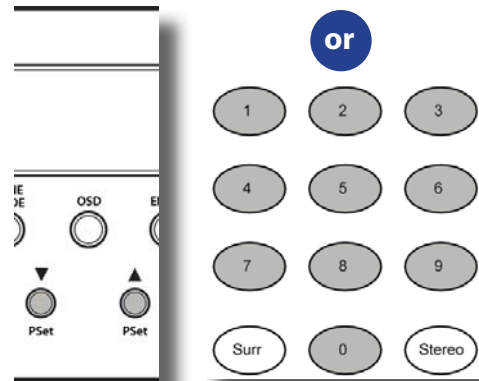

Tune Stations Directly

Tuning a frequency directly

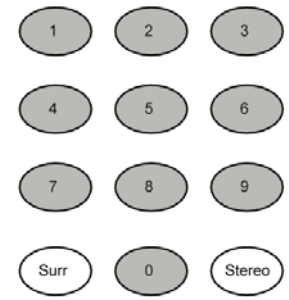

The Model 976 offers 20 station presets that can be used for both AM and FM stations.

To create memory presets for your favorite stations:

- 1. Tune to the station you want to set into memory.**
- 2. Press the “Mem” button on the remote.**
The number of the first available preset will flash on the left side of the display.
- 3. Press the ENTER button to use this preset.**
Alternatively, use the numeric keypad to select a specific preset number, then press ENTER. For presets 11 to 19, press 1 first then the second number. For preset 20, press 2 first and then 0.

Note: You can enter as many as 20 presets.

To select a preset station directly:

- 1. Select the tuner source.**
- 2. Use the numeric keypad on the remote control to enter the preset number of the station you want to listen to.**
The station will start playing and its frequency will be shown on the front panel display.

Hint: For faster entry of preset 1, enter 0 then 1 on the remote.

To select a preset station from the front panel:

- 1. Select the tuner source.**
- 2. Use the up or down buttons (▲ or ▼) on the front panel to scroll through the available presets.**

The Model 976 allows you to select radio stations directly if you know the station’s frequency.

To tune stations directly by frequency:

- 1. Select the tuner source.**
- 2. Select the band (AM or FM) you want to listen to.**
- 3. Press the DIRECT button on the remote control.**
- 4. Using the numeric keys on the remote, enter the frequency of the desired station.**

For example, for 1150 AM, push 1, 1, 5 and 0. For 106.9 FM, push 1, 0, 6, and 9. If you enter an invalid frequency, such as 1950 AM, the tuner will revert to the previously tuned station.

Select FM Mono

Switching to FM mono

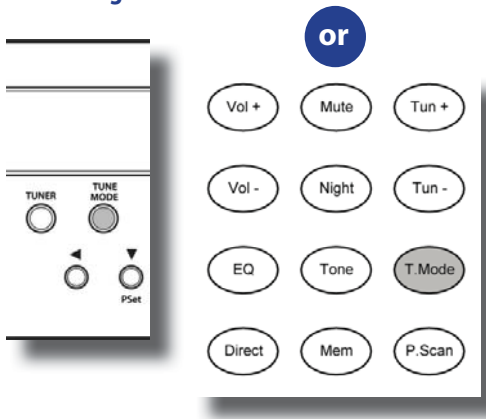

Front Panel Display



Sometimes FM reception is clearer in mono than in stereo. If you're hearing a lot of interference or static in your FM signal, try listening in mono to see if it clears up. The same signal will play from the left and right speakers, but it will probably be clearer.

To select FM mono:

- 1. When you are listening to an FM station, press the T.MODE button on the remote control or TUNE MODE on the front panel.**
The sound will change from stereo to mono, and the front panel display will show the mode as shown above.
- 2. So switch back to stereo, press the T.MODE button on the remote or TUNE MODE on the front panel again.**
The front panel display will indicate that you are back in FM stereo mode.

Care and Maintenance

Avoid using volatile, abrasive, or spray cleaners



Turn the unit off

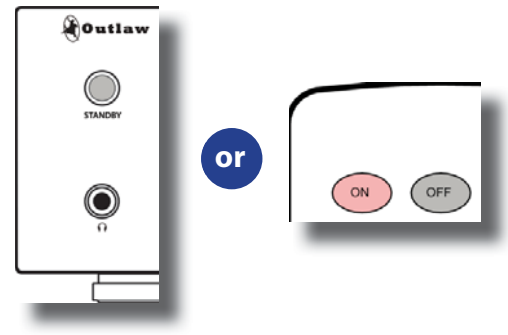

Chapter 6 Contents

- 42 Cleaning
- 42 When You Are Away
- 43 System Reset
- 44 Troubleshooting
- 45 Specifications
- 46 Model 976 Connection Record Chart
- 47 Outlaw Audio Limited Warranty

When the Model 976 becomes dirty, wipe it with a clean, soft, dry cloth. For tougher dirt or stains, first unplug the Model 976, then wipe the surface with a slightly dampened soft cloth. Wipe dry immediately with a dry cloth. Wait one hour before plugging the unit back in to make sure that all moisture used in cleaning has dried.

NEVER use benzene, thinner, alcohol or any other volatile cleaning agent. Do not use abrasive cleaners, as they may damage the finish of the metal parts. Avoid spraying insecticide, waxes, polishing agents, or any aerosol product near the unit.

If you will not be using your home theater system for an extended period of time, it is always a good idea to turn the unit off using the OFF button on the remote or the STANDBY button on the front panel. This will reduce power consumption and maximize the life of the internal components.

System Reset

Resetting the Model 976 to factory defaults

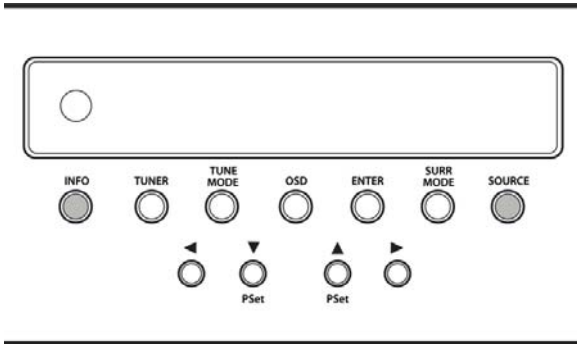

In rare cases the Model 976's internal processor may freeze or lock-up causing abnormal operation. This is common to all microprocessor-controlled devices when the unit is subject to excessive static discharge, AC line noise or power spikes.

In most cases it is easy to solve this problem by simply unplugging the Model 976 from its AC power source for about 5 minutes. After waiting, reconnect the power cord and turn the unit on. If the unit functions normally, no further action is needed.

In the event that the unit still does not operate properly, it may be necessary to manually reset the processor. Note, however, that when the processor is reset you will lose all settings including speaker setup, input setup and tuner presets. For this reason, we strongly recommend that you record these settings on the chart provided on page 46 of this manual so that it is easy to restore them after resetting the processor.

To reset the unit:

- 1. Turn off any connected amplifiers.**
- 2. Simultaneously press the INFO and SOURCE buttons on the front panel until the front panel displays RESET.**
This will take about five seconds.
- 3. Release the buttons and wait a few more seconds while the Model 976 resets itself.**
It will then power off automatically.
- 4. Turn the unit back on again.**
The Model 976 will return to its factory settings.
- 5. Go back through the steps outlined in the System Setup section (see page 23) to restore your Model 976's proper configuration and calibration.**

Note: If the manual reset does not solve the problem, contact Outlaw Audio for further advice.

Troubleshooting Guide

Your new Model 976 is designed to provide years of trouble-free operation. However, the complexity of today's sophisticated home theater systems means that you might encounter an occasional problem with your system and the Model 976.

Listed below are some of the more common issues you could encounter. For additional hints, we suggest that you look at the Support/FAQ section of our website at www.outlawaudio.com. Or enter the Model 976 Section of our Outlaw Saloon.

If your problem persists, please contact us via e-mail at customer.service@outlawaudio.com , or call us at 866-OUTLAWS (688-5297) or 866-OUTLAWA (688-5292).

Symptom	Possible Cause	Solution Options
Unit does not turn on when remote or front panel buttons are pressed	<ul style="list-style-type: none"> ▶ No AC Power ▶ Power strip or conditioner turned off 	<ul style="list-style-type: none"> ▶ Make certain AC power cord is plugged into a live outlet. ▶ Make certain power strip or power conditioner is turned on, if applicable.
No sound from speakers even though Model 976 is on	<ul style="list-style-type: none"> ▶ Amplifier not on ▶ Amplifier(s) disconnected ▶ Speakers disconnected 	<ul style="list-style-type: none"> ▶ Check to be sure amplifier is on. ▶ Check connections between Model 976 and amplifier(s). ▶ Check connections between amplifier and speakers
No sound from digital audio source	<ul style="list-style-type: none"> ▶ Input not selected ▶ Input not properly configured 	<ul style="list-style-type: none"> ▶ Make certain the correct digital input (HDMI, coaxial, or optical) is associated to the source.
No sound from subwoofer	<ul style="list-style-type: none"> ▶ Subwoofer off ▶ Subwoofer disconnected ▶ Speaker setup in Model 976 not properly configured 	<ul style="list-style-type: none"> ▶ Make sure the subwoofer is plugged in, powered up, and that its volume is turned up. ▶ Make sure the cable between the Model 976's subwoofer output and the subwoofer's line input is connected and in good condition. ▶ Check the settings in the Model 976's Speaker Setup menu to make sure the subwoofer output is activated.
Buzzing or noise in AM and FM programs	<ul style="list-style-type: none"> ▶ Station incorrectly tuned ▶ Antenna improperly positioned ▶ Antenna cable disconnected or damaged ▶ Wrong type of antenna used 	<ul style="list-style-type: none"> ▶ Push the tune + and – buttons on the remote a few clicks in either direction to see if sound improves. ▶ Change the antenna position and see if sound improves. ▶ Check the connection between the antenna and the Model 976's antenna jacks to make sure it is connected and in good condition. ▶ Make sure you're using an FM antenna for FM and an AM antenna for AM.
Unit produces a flashing picture, no picture, audio popping or crackling sound, snow on image, or no audio, though the Channel Balance tones (Pink Noise generator) does produce audio.	<ul style="list-style-type: none"> ▶ Incomplete HDMI handshake 	<p>Resolving an HDMI handshake issue is easiest when the results of unplugging and re-connecting in real time.</p> <ul style="list-style-type: none"> ▶ Try a "hot swap" of the HDMI cables at the back of the processor. ▶ Make sure that the source devices, TV, and processor are turned on. ▶ Make sure that HDMI cables are rated for 4K HDR ("high speed") use when connecting to 4K sources or to a 4K HDTV. ▶ Ensure each end of the cable is plugged in securely. ▶ Try plugging and unplugging the HDMI cable(s), at the back of the processor, one to three times in succession. ▶ Observe the playback material to verify the connected HDMI cable has achieved a solid connection. It takes 3 to 7 seconds (handshaking time) to see a result. <ul style="list-style-type: none"> »» When it appears a solid connection is made, you may try to gently wiggle the cable at the back of the processor, while observing that neither the Video nor the Audio is affected by this. If you are able to affect the video or audio, then repeat the "hot swap" procedure. »» Once a solid connection is achieved, it should not be necessary to repeat this procedure.
No sound from one or more channels	<ul style="list-style-type: none"> ▶ Poor connections ▶ Incorrect surround mode ▶ Incorrect speaker configuration 	<ul style="list-style-type: none"> ▶ Check interconnects to the amplifier and connections from the amplifier to the speakers. ▶ Check surround mode to confirm it provides output to all speakers. ▶ Make certain all speakers are properly configured in the Speaker Setup menu.
Remote control does not function	<ul style="list-style-type: none"> ▶ Weak battery in remote ▶ Remote sensor obscured ▶ Remote used at an angle to the front panel 	<ul style="list-style-type: none"> ▶ Replace the batteries in the remote. ▶ Make sure there's nothing in between you and the front panel of the Model 976. ▶ Try using the remote from directly in front of the Model 976.

Specifications

Analog Section

Input Impedance	47 K Ω
Output Impedance (Main-RCA)	<1 K Ω
Pre Out	4 V
Maximum Output	9 V
Volume Range (Main)	-90dB to +0dB (1dB resolution)
Frequency Response	10 Hz to 80 KHz \pm 1 dB
S/N Ratio (IHF-A)	-112 dB

Bass Management

Crossover Frequency Choices (Small Speaker Setting)	40/50/60/70/80/90/100/110/ 120/130/140/150H/200Hz
High-Pass (Satellite) Crossover Slope	12 dB/octave (2nd order)
Low-Pass (Subwoofer) Crossover Slope	24 dB/octave (4th order)

Tone Controls

Bass Center Frequency/Range	100 Hz \pm 10 dB
Treble Center Frequency/Range	10 KHz \pm 10 dB

FM Tuner Section

Sensitivity	
IHF	10 dBu typ.
50dB S/N	13 dBu typ.
S/N Ratio	
Mono	70 dB
Stereo	67 dB
Distortion	
Mono	0.2%
Stereo	0.3%
Stereo Separation	40 dB typ.
Adjacent Channel Selectivity	70 dB \pm 400 KHz
IF Rejection Ratio	120 dB
Frequency Response	20 Hz to 15 KHz \pm 1.5 dB

AM Tuner Section

Sensitivity (20dB S/N)	300 μ V
S/N	-45 dB
Selectivity	25 dB
Distortion	0.7%

Digital Audio

S/PDIF Coax Impedance	75 Ω
S/PDIF Coax Signal Strength	0.5Vp-p
Digital Signal Processor	TI-DA808

General

Supply Voltage	120V, 60Hz only
Standby Power Consumption (Power Off)	0.5 W
Trigger Output Sequential Delay	50 mA @ 5 VDC
Dimensions (H/W/D)	4.625 x 17 x 11 in 117.5 x 431.8 x 279.4 mm
Weight	12.0 lb 5.44 kg

Model 976 Connection Record Chart

Use this chart to record the components connected to your Model 976, as well as which type of input (HDMI, analog, coaxial, etc.) is used.

Additionally, we recommend that you record all of the video and audio settings made during setup of your Model 976 for future reference. In the event that you need to reset your unit to its factory defaults, or after performing a software upgrade, you can use the information here to restore your Model 976 to your preferred configuration.

CABLE/SAT		DISC		GAME		MEDIA	
Device		Device		Device		Device	
Video	Audio	Video	Audio	Video	Audio	Video	Audio
HDMI 1 <input type="checkbox"/>	HDMI <input type="checkbox"/>	HDMI 1 <input type="checkbox"/>	HDMI <input type="checkbox"/>	HDMI 1 <input type="checkbox"/>	HDMI <input type="checkbox"/>	HDMI 1 <input type="checkbox"/>	HDMI <input type="checkbox"/>
HDMI 2 <input type="checkbox"/>	Coax 1 <input type="checkbox"/>	HDMI 2 <input type="checkbox"/>	Coax 1 <input type="checkbox"/>	HDMI 2 <input type="checkbox"/>	Coax 1 <input type="checkbox"/>	HDMI 2 <input type="checkbox"/>	Coax 1 <input type="checkbox"/>
HDMI 3 <input type="checkbox"/>	Coax 2 <input type="checkbox"/>	HDMI 3 <input type="checkbox"/>	Coax 2 <input type="checkbox"/>	HDMI 3 <input type="checkbox"/>	Coax 2 <input type="checkbox"/>	HDMI 3 <input type="checkbox"/>	Coax 2 <input type="checkbox"/>
HDMI 4 <input type="checkbox"/>	Opt 1 <input type="checkbox"/>	HDMI 4 <input type="checkbox"/>	Opt 1 <input type="checkbox"/>	HDMI 4 <input type="checkbox"/>	Opt 1 <input type="checkbox"/>	HDMI 4 <input type="checkbox"/>	Opt 1 <input type="checkbox"/>
HDMI 5 <input type="checkbox"/>	Opt 2 <input type="checkbox"/>	HDMI 5 <input type="checkbox"/>	Opt 2 <input type="checkbox"/>	HDMI 5 <input type="checkbox"/>	Opt 2 <input type="checkbox"/>	HDMI 5 <input type="checkbox"/>	Opt 2 <input type="checkbox"/>
HDMI 6 <input type="checkbox"/>	Analog 1 <input type="checkbox"/>	HDMI 6 <input type="checkbox"/>	Analog 1 <input type="checkbox"/>	HDMI 6 <input type="checkbox"/>	Analog 1 <input type="checkbox"/>	HDMI 6 <input type="checkbox"/>	Analog 1 <input type="checkbox"/>
	Analog 2 <input type="checkbox"/>		Analog 2 <input type="checkbox"/>		Analog 2 <input type="checkbox"/>		Analog 2 <input type="checkbox"/>
Triggers	Analog 3 <input type="checkbox"/>	Triggers	Analog 3 <input type="checkbox"/>	Triggers	Analog 3 <input type="checkbox"/>	Triggers	Analog 3 <input type="checkbox"/>
Trigger 1 <input type="checkbox"/>	Analog 4 <input type="checkbox"/>	Trigger 1 <input type="checkbox"/>	Analog 4 <input type="checkbox"/>	Trigger 1 <input type="checkbox"/>	Analog 4 <input type="checkbox"/>	Trigger 1 <input type="checkbox"/>	Analog 4 <input type="checkbox"/>
Trigger 2 <input type="checkbox"/>	7.1 Direct <input type="checkbox"/>	Trigger 2 <input type="checkbox"/>	7.1 Direct <input type="checkbox"/>	Trigger 2 <input type="checkbox"/>	7.1 Direct <input type="checkbox"/>	Trigger 2 <input type="checkbox"/>	7.1 Direct <input type="checkbox"/>
Lip sync delay: _____ ms		Lip sync delay: _____ ms		Lip sync delay: _____ ms		Lip sync delay: _____ ms	

SERVER		AUX		TV		BLUETOOTH	TUNER
Device		Device		Device		Device	Device
Video	Audio	Video	Audio	Triggers	Audio	Video	Video
HDMI 1 <input type="checkbox"/>	HDMI <input type="checkbox"/>	HDMI 1 <input type="checkbox"/>	HDMI <input type="checkbox"/>	Trigger 1 <input type="checkbox"/>	HDMI ARC <input type="checkbox"/>	HDMI 1 <input type="checkbox"/>	HDMI 1 <input type="checkbox"/>
HDMI 2 <input type="checkbox"/>	Coax 1 <input type="checkbox"/>	HDMI 2 <input type="checkbox"/>	Coax 1 <input type="checkbox"/>	Trigger 2 <input type="checkbox"/>	Coax 1 <input type="checkbox"/>	HDMI 2 <input type="checkbox"/>	HDMI 2 <input type="checkbox"/>
HDMI 3 <input type="checkbox"/>	Coax 2 <input type="checkbox"/>	HDMI 3 <input type="checkbox"/>	Coax 2 <input type="checkbox"/>		Coax 2 <input type="checkbox"/>	HDMI 3 <input type="checkbox"/>	HDMI 3 <input type="checkbox"/>
HDMI 4 <input type="checkbox"/>	Opt 1 <input type="checkbox"/>	HDMI 4 <input type="checkbox"/>	Opt 1 <input type="checkbox"/>		Opt 1 <input type="checkbox"/>	HDMI 4 <input type="checkbox"/>	HDMI 4 <input type="checkbox"/>
HDMI 5 <input type="checkbox"/>	Opt 2 <input type="checkbox"/>	HDMI 5 <input type="checkbox"/>	Opt 2 <input type="checkbox"/>		Opt 2 <input type="checkbox"/>	HDMI 5 <input type="checkbox"/>	HDMI 5 <input type="checkbox"/>
HDMI 6 <input type="checkbox"/>	Analog 1 <input type="checkbox"/>	HDMI 6 <input type="checkbox"/>	Analog 1 <input type="checkbox"/>		Analog 1 <input type="checkbox"/>	HDMI 6 <input type="checkbox"/>	HDMI 6 <input type="checkbox"/>
	Analog 2 <input type="checkbox"/>		Analog 2 <input type="checkbox"/>		Analog 2 <input type="checkbox"/>		
Triggers	Analog 3 <input type="checkbox"/>	Triggers	Analog 3 <input type="checkbox"/>		Analog 3 <input type="checkbox"/>	Triggers	Triggers
Trigger 1 <input type="checkbox"/>	Analog 4 <input type="checkbox"/>	Trigger 1 <input type="checkbox"/>	Analog 4 <input type="checkbox"/>		Analog 4 <input type="checkbox"/>	Trigger 1 <input type="checkbox"/>	Trigger 1 <input type="checkbox"/>
Trigger 2 <input type="checkbox"/>	7.1 Direct <input type="checkbox"/>	Trigger 2 <input type="checkbox"/>	7.1 Direct <input type="checkbox"/>		7.1 Direct <input type="checkbox"/>	Trigger 2 <input type="checkbox"/>	Trigger 2 <input type="checkbox"/>
Lip sync delay: _____ ms		Lip sync delay: _____ ms		Lip sync delay: _____ ms		Lip sync delay: _____ ms	Lip sync delay: _____ ms

INPUT SURROUND DEFAULT

Input	Default Surround Mode (Surr. Default)							
Cable/Sat	PL II/Ilx Movie <input type="checkbox"/>	PLII/Ilx Music <input type="checkbox"/>	PLII/Ilx Game <input type="checkbox"/>	Neo6 Cinema <input type="checkbox"/>	Neo6 Music <input type="checkbox"/>	All Ch. Stereo <input type="checkbox"/>	Auto <input type="checkbox"/>	
Disc	PL II/Ilx Movie <input type="checkbox"/>	PLII/Ilx Music <input type="checkbox"/>	PLII/Ilx Game <input type="checkbox"/>	Neo6 Cinema <input type="checkbox"/>	Neo6 Music <input type="checkbox"/>	All Ch. Stereo <input type="checkbox"/>	Auto <input type="checkbox"/>	
Game	PL II/Ilx Movie <input type="checkbox"/>	PLII/Ilx Music <input type="checkbox"/>	PLII/Ilx Game <input type="checkbox"/>	Neo6 Cinema <input type="checkbox"/>	Neo6 Music <input type="checkbox"/>	All Ch. Stereo <input type="checkbox"/>	Auto <input type="checkbox"/>	
Media	PL II/Ilx Movie <input type="checkbox"/>	PLII/Ilx Music <input type="checkbox"/>	PLII/Ilx Game <input type="checkbox"/>	Neo6 Cinema <input type="checkbox"/>	Neo6 Music <input type="checkbox"/>	All Ch. Stereo <input type="checkbox"/>	Auto <input type="checkbox"/>	
Server	PL II/Ilx Movie <input type="checkbox"/>	PLII/Ilx Music <input type="checkbox"/>	PLII/Ilx Game <input type="checkbox"/>	Neo6 Cinema <input type="checkbox"/>	Neo6 Music <input type="checkbox"/>	All Ch. Stereo <input type="checkbox"/>	Auto <input type="checkbox"/>	
Aux	PL II/Ilx Movie <input type="checkbox"/>	PLII/Ilx Music <input type="checkbox"/>	PLII/Ilx Game <input type="checkbox"/>	Neo6 Cinema <input type="checkbox"/>	Neo6 Music <input type="checkbox"/>	All Ch. Stereo <input type="checkbox"/>	Auto <input type="checkbox"/>	
TV	PL II/Ilx Movie <input type="checkbox"/>	PLII/Ilx Music <input type="checkbox"/>	PLII/Ilx Game <input type="checkbox"/>	Neo6 Cinema <input type="checkbox"/>	Neo6 Music <input type="checkbox"/>	All Ch. Stereo <input type="checkbox"/>	Auto <input type="checkbox"/>	
Bluetooth	PL II/Ilx Movie <input type="checkbox"/>	PLII/Ilx Music <input type="checkbox"/>	PLII/Ilx Game <input type="checkbox"/>	Neo6 Cinema <input type="checkbox"/>	Neo6 Music <input type="checkbox"/>	All Ch. Stereo <input type="checkbox"/>	Auto <input type="checkbox"/>	
Tuner	PL II/Ilx Movie <input type="checkbox"/>	PLII/Ilx Music <input type="checkbox"/>	PLII/Ilx Game <input type="checkbox"/>	Neo6 Cinema <input type="checkbox"/>	Neo6 Music <input type="checkbox"/>	All Ch. Stereo <input type="checkbox"/>	Auto <input type="checkbox"/>	

SPEAKER SIZE

Front	Lg <input type="checkbox"/>	Sm <input type="checkbox"/>	
Center	Lg <input type="checkbox"/>	Sm <input type="checkbox"/>	None <input type="checkbox"/>
Surround	Lg <input type="checkbox"/>	Sm <input type="checkbox"/>	None <input type="checkbox"/>
Surr. Back	Lg <input type="checkbox"/>	Sm <input type="checkbox"/>	None <input type="checkbox"/>
Sub	Yes <input type="checkbox"/>	No <input type="checkbox"/>	

CROSSOVER

Front	_____ Hz
Center	_____ Hz
Surround	_____ Hz
Surr. Back	_____ Hz

SPEAKERS

	Distance	Trim
Front Left	_____ FT <input type="checkbox"/> / M <input type="checkbox"/>	_____ dB
Center	_____ FT <input type="checkbox"/> / M <input type="checkbox"/>	_____ dB
Front Right	_____ FT <input type="checkbox"/> / M <input type="checkbox"/>	_____ dB
Surround Right	_____ FT <input type="checkbox"/> / M <input type="checkbox"/>	_____ dB
Surr. Back Right	_____ FT <input type="checkbox"/> / M <input type="checkbox"/>	_____ dB
Surr. Back Left	_____ FT <input type="checkbox"/> / M <input type="checkbox"/>	_____ dB
Surround Left	_____ FT <input type="checkbox"/> / M <input type="checkbox"/>	_____ dB
Subwoofer	_____ FT <input type="checkbox"/> / M <input type="checkbox"/>	_____ dB

AUDIO

Treble	_____ dB
Bass	_____ dB
Dolby Pro Logic II	
Panorama	On <input type="checkbox"/> Off <input type="checkbox"/>
Center Width	_____ dB
Dimension	_____ dB
DTS HD Speaker Remap	1 <input type="checkbox"/> 5 <input type="checkbox"/>
Neo 6 Center Gain	_____ dB
DSP Bypass	On <input type="checkbox"/> Off <input type="checkbox"/>

30-Day Satisfaction Guarantee

This product is guaranteed to satisfy all your needs for a high quality preamp/processor. If for any reason, you are not completely satisfied with it, please contact us at 866-OUTLAWS (688-5297) within 30 days of receipt of the unit and you will receive a return authorization.

The original box and packing materials are required for all returns. We recommend that you keep the packing (even after 30 days) so that if you ever move, or the preamp/processor requires service, the unit will be adequately protected.

If you decide to return the preamp/processor, the only cost you will be responsible for is the original shipping charge at time of purchase. When your unit arrives, we will inspect it to insure that it was shipped back to us in original condition with all of the accessories. Upon satisfactory inspection, we will issue a credit for your original purchase price less your original outbound freight cost.

Outlaw Audio Limited Warranty

This warranty protects the owner of the Outlaw Model 976 Preamp/Processor (the PRODUCT) for three (3) years from the date of purchase*.

This warranty covers all defects in material and workmanship with the following specific exceptions. These are:

- ▶ Damage caused by improper installation or adjustment
- ▶ Damage caused by accident, unreasonable use or neglect
- ▶ Damage from failure to follow instructions contained in this Owner's Manual
- ▶ Damage from the performance of repairs by someone not authorized by Outlaw Audio
- ▶ Any unit on which the serial number has been effaced, modified, or removed
- ▶ Damage occurring during shipment
- ▶ Units which have been altered or modified in design, appearance or construction

This warranty covers only the actual defects within the PRODUCT itself. IT DOES NOT cover costs of installation in (or removal from) a fixed installation, or normal set-up, claims based on any misrepresentation by the seller, or performance variations resulting from installation related circumstances such as signal quality, AC power or incompatibilities with speakers and/or other system components.

During the warranty period, Outlaw Audio will, at its option, either repair the defect, or replace the defective product, or the defective parts, or components thereof at no charge to the owner for parts and labor covered by this warranty. If necessary repairs are not covered by this warranty, or if a unit is examined which is not in need of repair, you will be charged for the repairs and/or the examination. If non-warranted repairs are needed, we will notify you of the estimated cost and ask for your authorization to perform said repairs.

You must pay shipping charges incurred in getting your Product to the factory. We will pay the return shipping charges if the repairs are covered by the warranty. Please save the original shipping cartons as the unit MUST be returned in the original carton and packing. (Replacement cartons are available at a modest charge.)

If your product needs service, please contact us at support.outlawaudio.com.

You will need to present the original bill of sale to establish the date of purchase. In the event that the proof of purchase cannot be established with the original receipt, the warranty period shall be determined by the earliest date of manufacture shown on the unit, provided that the serial number label has not been altered in any manner, or by our records relating to that serial number.

In the event that you wish to return your Outlaw Product back to us, for any reason, please call to arrange for a Return Authorization Number. This will insure that your problem is discussed with a service technician who will determine if there is a quick solution to your problem.

Outlaw Audio shall not be liable for, in any way responsible for, any incidental or consequential damages of any kind. Some states do not allow limitations on how long an implied warranty lasts and/or do not allow the exclusion of incidental or consequential damages, therefore, the limitations and exclusions stated herein may not apply to you. This warranty gives you specific legal rights; and you may also have other rights which vary from state to state.

THERE ARE NO WARRANTIES GIVEN BY OUTLAW AUDIO WHICH EXTEND BEYOND THE DESCRIPTION GIVEN HEREIN. ANY IMPLIED WARRANTIES OF FITNESS FOR PURPOSE SOLD, MERCHANTABILITY, DESCRIPTION, QUALITY OR ANY OTHER MATTERS ARE LIMITED TO THE TERMS OF THE EXPRESSED LIMITED WARRANTY STATED HEREIN.

Products are sold on the basis of specifications applicable at the time of sales. Outlaw Audio shall have no obligation to modify products once they have been sold.

This warranty is applicable only in the United States.

For applicability in other countries, please call Outlaw Audio, LLC.

© Outlaw Audio LLC.

*This warranty is limited to ninety (90) days from the date of original purchase for any Outlaw Audio product that is used for professional or commercial purposes, or any other income-producing purpose.